



DEEP CYCLE-SOLAR SERIES 4000

BATTERY TYPE VOLTS 8 **8 HHG 31PS**

DIMENSIONS

LENGTH	686 MM	27	INCHES
WIDTH	203 MM	8	INCHES
HEIGHT	302 MM	11 7/8	INCHES

WEIGHT DRY	58 KG	128	LBS.
WEIGHT WET	76 KG	167	LBS.

CONTAINER CONSTRUCTION

INNER CONTAINER	POLYPROPYLENE
INNER COVER	POLYPROPYLENE - HEAT SEALED TO INNER CONTAINER
OUTER CONTAINER	HIGH DENSITY POLYETHYLENE
OUTER COVER	HIGH DENSITY POLYETHYLENE SNAP FIT TO OUTER CONTAINER
HANDLES	MOLDED

PLATES PER CELL 31

ELECTROLYTE RESERVE ABOVE PLATES 70 MM 2.75 INCHES

DESIGN CRITREA 7 YEAR WARRANTY 1300 CYCLES 10 YEAR LIFE

POSITIVE PLATE DIMENSION

HEIGHT	140 MM	5.500	INCHES
WIDTH	143 MM	5.625	INCHES
THICKNESS	3.43 MM	0.135	INCHES

NEGATIVE PLATE DIMENSION

HEIGHT	140 MM	5.500	INCHES
WIDTH	137 MM	5.375	INCHES
THICKNESS	2.24 MM	0.088	INCHES

SEPARATOR SEPARATOR THICKNESS 0.081 INCH
INSULATION 0.020" GLASS MAT

TERMINALS FLAG WITH STAINLESS STEEL NUTS AND BOLTS

COLD CRANK CCA	0°F / -17.8°C	1444	RESERVE	696
MCA	32°F / 0°C	1805	MINUTES AT 25A	

CAPACITY 20 HR RATE 344

		CAP / AH	CURRENT / AMPS
CAPACITY AT THE 100 HOUR RATE	1.265 SP. GR.	458	4.58
CAPACITY AT THE 72 HOUR RATE	1.265 SP. GR.	433	6.02
CAPACITY AT THE 50 HOUR RATE	1.265 SP. GR.	409	8.19
CAPACITY AT THE 24 HOUR RATE	1.265 SP. GR.	354	14.8
CAPACITY AT THE 20 HOUR RATE	1.265 SP. GR.	344	17.2
CAPACITY AT THE 15 HOUR RATE	1.265 SP. GR.	323	21.6
CAPACITY AT THE 12 HOUR RATE	1.265 SP. GR.	306	25.5
CAPACITY AT THE 10 HOUR RATE	1.265 SP. GR.	292	29.2
CAPACITY AT THE 8 HOUR RATE	1.265 SP. GR.	275	34.4
CAPACITY AT THE 6 HOUR RATE	1.265 SP. GR.	255	42.4
CAPACITY AT THE 5 HOUR RATE	1.265 SP. GR.	241	48
CAPACITY AT THE 4 HOUR RATE	1.265 SP. GR.	224	56
CAPACITY AT THE 3 HOUR RATE	1.265 SP. GR.	203	68
CAPACITY AT THE 2 HOUR RATE	1.265 SP. GR.	175	88
CAPACITY AT THE 1 HOUR RATE	1.265 SP. GR.	124	124



PART NUMBER: 8-HHG-31P
WEIGHT WET: 167 LB / 76 KG
WEIGHT DRY: 128 LB / 58 KG
CAPACITY: 344 AH 20 HR
CCA @ 0°F / -17.8 °C: 1,445 A
CCA @ 32°F / 0 °C: 1,806 A
VOLTAGE: 8 V
OVERALL DIMENSIONS: 27x 8x 11 7/8"
MAX HEIGHT WITH OPTIONAL HYDROCAPS: 12.38" / 316 MM

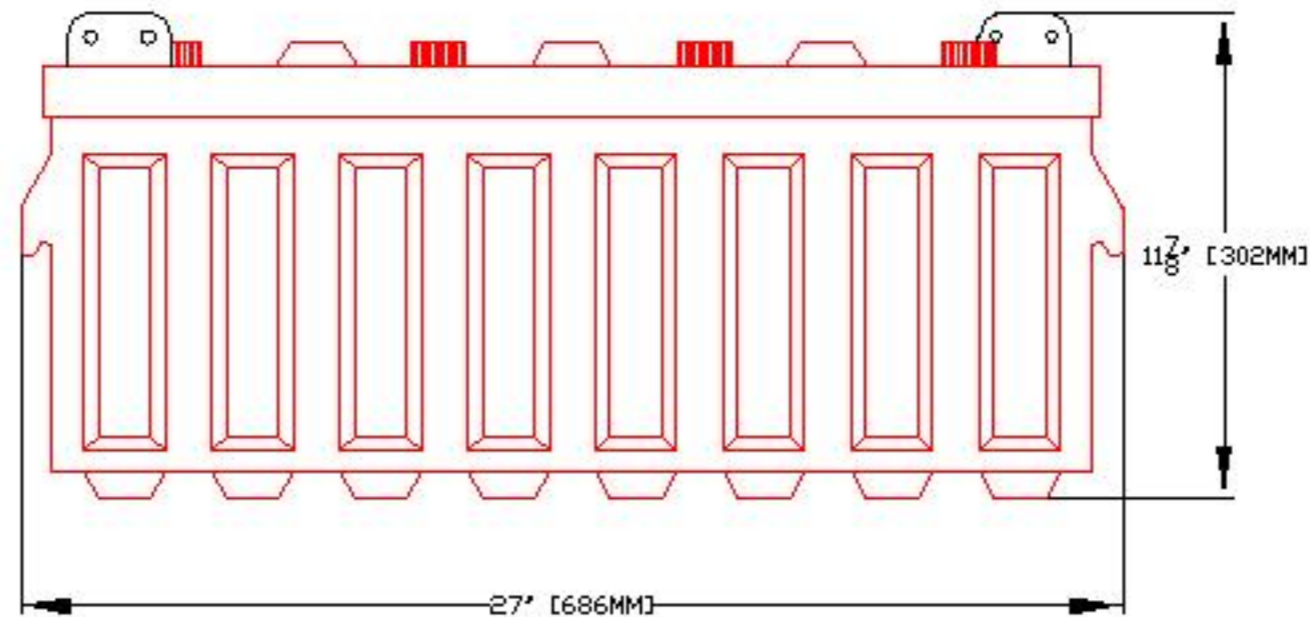
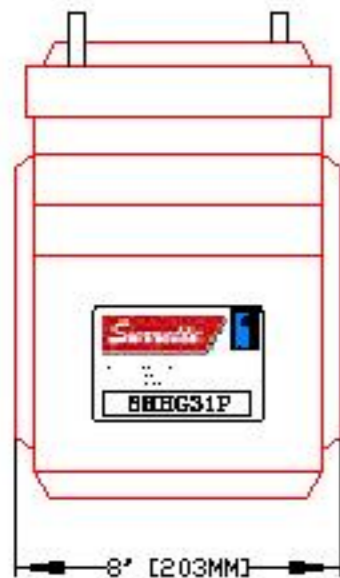
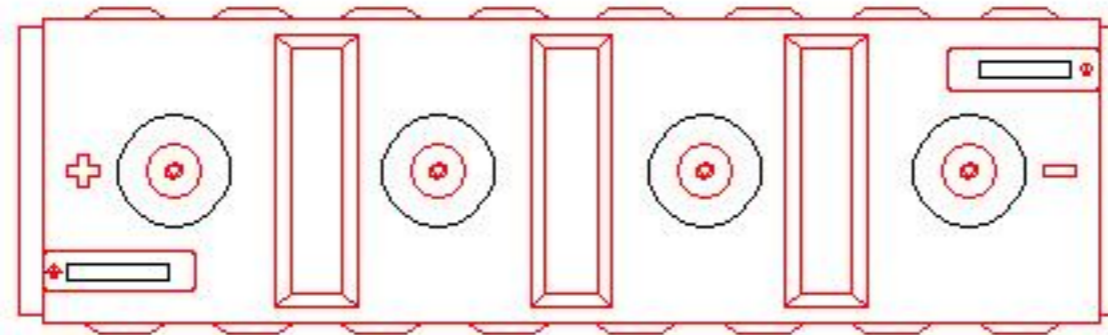

BATTERY COMPANY LIMITED SPRUEHILL / NOVA SCOTIA / CANADA PRODUCT OF CANADA	
TITLE:	8HHG31P
DESCRIPTION:	8V DEEP CYCLE 400/4000 SERIES
CONTACT INFO:	WEB: WWW.SURRETTE.COM E-MAIL: SALES@SURRETTE.COM PHONE: 1-800-681-9914
SCALE:	1" = 6" 1" = 4" JPEG 6.5" X 11" 11" X 17" NOT TO SCALE
Drawn by:	Approved By:
S. WILES	D. SURRETTE
DATE: 20-Feb-01	REVISION 1.1
DRAWING NO: DWG 011, BD8HHG31P	