



# PVP1100 to PVP5200 String Inverters

## Proven Reliability – With Integrated AC and DC PV System Disconnect Listed to the UL 98 Standard

PV Powered, Inc. continues to deliver industry-leading reliability and technical innovations that lower the total cost of PV systems installation. PV Powered is now the only manufacturer of a residential inverter-integrated AC/DC PV System Disconnect that is listed to the UL 98 Standard. The UL 98 Standard, called “Enclosed and Dead-front Switches,” ensures the integrated PV Powered disconnect meets all installation and inspection requirements of a PV System Disconnect.

Housed within an NEC Compliant wire raceway, PV Powered’s innovative disconnect consists of one enclosure with generous working room for installation. In addition to providing for a single point of connection from the utility service and PV array, the wire raceway’s optimized knockout locations also provide options for side, bottom and back entry with minimized conduit bending. The wire raceway enables flush side-by-side mounting, eliminating the need for extra equipment and resulting in a cleaner, less expensive installation.

PV Powered’s string inverters are backed by the industry’s first nation-wide ten year warranty and equipment replacement program. Optional performance monitoring is available which includes low cost, secure web-based access to inverter status and performance history.

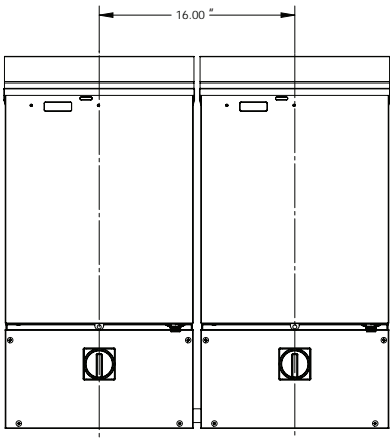

**Example of Side-by-side Mounting on Standard Stud Spacing**



### FEATURES

#### Industry-Leading Reliability

- Endurance tested to 20 year operating life
- Lowest part counts and fewest interconnects eliminate common failure points
- Field-proven technology with thousands of units installed nationwide

#### Integrated AC and DC PV System Disconnect

- Listed to UL 98 Standard for use with PV Powered UL 1741 Listed string inverters
- Robust testing of switch mechanism to UL 98 Standard
- Single AC/DC switch visible and lockable in the OFF position
- NEC Compliant internal wire raceway enables side-by-side mounting
- Direct-to-wall surface enclosure design allows for easy access and installation

#### Easy Installation

- Factory integrated inverter and PV System Disconnect eliminates the need for extra equipment
- Integrated disconnect reduces conduit connection points saving installation time and material cost
- Field-configurable positive ground applications with simple jumper selection
- Optimally placed knockouts for a variety of conduit routing options

#### Installer-Focused Support

- No special purchase requirements to get the best technical support in the industry
- Live technical phone support
- Economical performance monitoring options



All PV Powered products are designed and manufactured in the U.S., are fully compliant with the Buy American Act, and qualify for projects funded by the federal stimulus package.

20720 Brinson Boulevard  
PO Box 7348  
Bend, OR 97708

1-541-312-3832  
WWW.PVPOWERED.COM

## DIMENSIONS

### PVP1100 to PVP3500

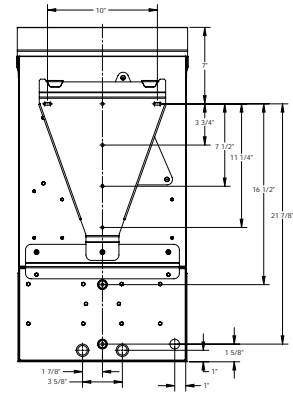
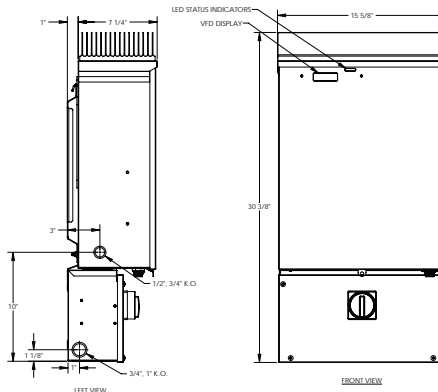
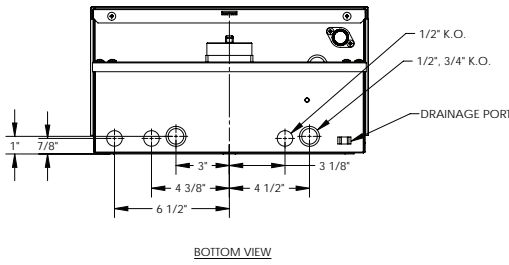

### PVP4600, PVP4800, PVP5200

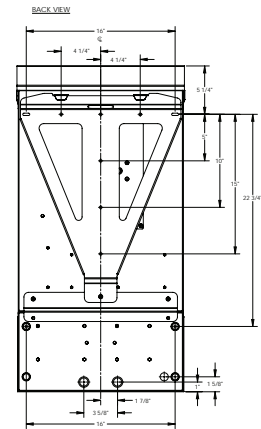
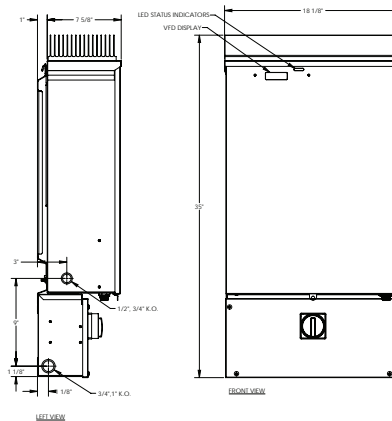
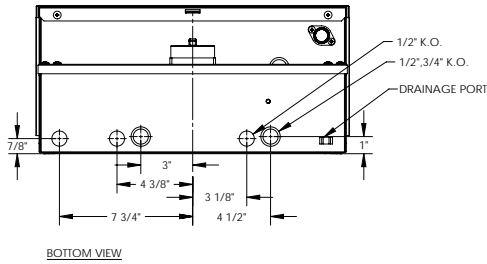

## ELECTRICAL SPECIFICATIONS

MODEL	PVP1100	PVP2000	PVP2500	PVP2800	PVP3000	PVP3500	PVP4600	PVP4800	PVP5200
Continuous Output Power (watts)	1100	2000	2500	2800	3000	3500	4600	4800	5200
Weighted CEC Efficiency (%)	90.5	92	94.5	92	93.5	95.5	95.5	96	96
Maximum DC Input Voltage (VOC)	500	500	500	500	500	500	500	500	500
DC Voltage Operating Range (V)	115-450	115-450	140-450	180-450	170-450	200-450	205-450	200-450	240-450
DC Minimum Start Voltage (V)	130	130	155	195	185	215	220	215	255
DC Maximum Current (A)	10	17.5	18	20	18	17.5	22.5	24	22
AC Maximum Continuous Current (A)	10	9	11	13	13	15	23	21	23
AC Nominal Voltage (V)	120	240	240	208	240	240	208	240	240
AC Output Voltage Range (V)	105.6-132.5	211-264	211-264	183-229	211-264	211-264	183-229	211-264	211-264
AC Frequency Range (Hz)	59.3-60.5	59.3-60.5	59.3-60.5	59.3-60.5	59.3-60.5	59.3-60.5	59.3-60.5	59.3-60.5	59.3-60.5

## MECHANICAL SPECIFICATIONS

MODEL	PVP1100	PVP2000	PVP2500	PVP2800	PVP3000	PVP3500	PVP4600	PVP4800	PVP5200	
Inverter with Factory-Integrated AC and DC PV System Disconnect										
NEMA 3R Steel Enclosure, Wall Mounted with Bracket Included										
Temperature	-25°C to 40°C									
Weight (lbs) with Disconnect	84.5	92.5	106.5	106.5	106.5	120.5	162	162	162	
Inverter with Disconnect Dimensions	30 3/8" H x 15 5/8" W x 8 1/4" D	30 3/8" H x 15 5/8" W x 8 1/4" D	30 3/8" H x 15 5/8" W x 8 1/4" D	30 3/8" H x 15 5/8" W x 8 1/4" D	30 3/8" H x 15 5/8" W x 8 1/4" D	30 3/8" H x 15 5/8" W x 8 1/4" D	30 3/8" H x 15 5/8" W x 8 1/4" D	35" H x 18 1/8" W x 8 5/8" D	35" H x 18 1/8" W x 8 5/8" D	35" H x 18 1/8" W x 8 5/8" D

## AGENCY APPROVALS

MODEL	PVP1100	PVP2000	PVP2500	PVP2800	PVP3000	PVP3500	PVP4600	PVP4800	PVP5200
-------	---------	---------	---------	---------	---------	---------	---------	---------	---------

UL 98 13th Edition, UL 1741 Nov 2005 Revision, CSA C22.2 107.1 2006 Revision, IEEE 1547 Compliant, FCC Class A & B