

SunMate™

Hot Air Solar Panel

by

ENVIRONMENTAL SOLAR SYSTEMS



**Instruction Manual For A Single Solar Panel
Mounted Over the Siding of a House.**

ENVIRONMENTAL SOLAR SYSTEMS, INC

www.environmentalsolarsystems.com

Patented and Made in USA

Revised 11/09

LEVEL



STUD FINDER



DRILL

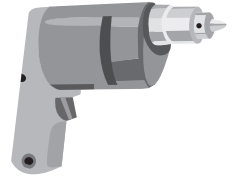

TAPE MEASURE

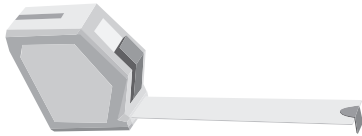

CAULKING GUN



DRILL INDEX

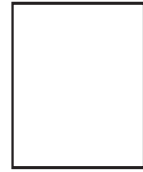

KEY HOLE SAW

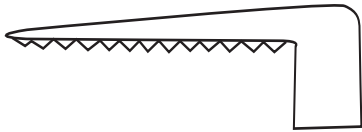

PROTRACTOR

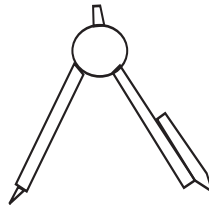

JIG SAW

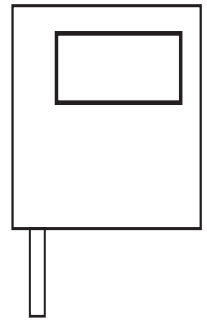

1/4" x 8" PILOT DRILL



PENCIL



TIN SNIPS

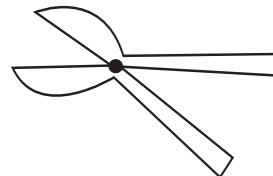

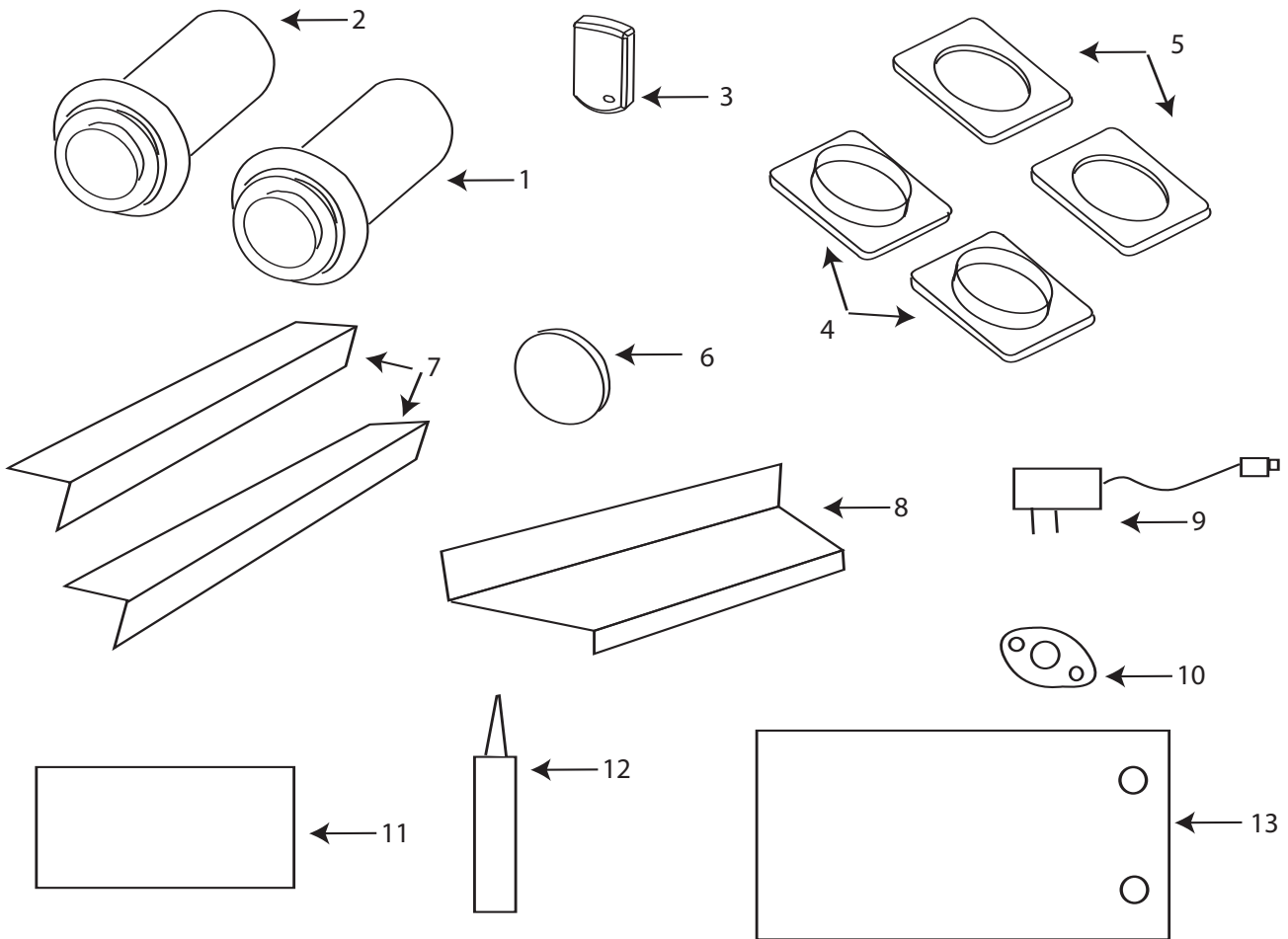

ITEM	PART NUMBER	DESCRIPTION
1	001	11" Long, 5" supply vent with fan installed
2	002	11" Long, 5" return vent
3	003	Wall thermostat
4	004	5" Wall Collar
5	005	Foam Gasket 1" Thick
6	006	Air Filter
7	007	Bottom and Top Mounting Bracket
8	008	Top Solar Panel Flashing
9	009	Energy Star 120VAC to 12VDC Transformer
10	0010	Snap Action Switch
11	0011	Hardware Pack
12	0012	Tube Silicone
13	0013	Card Board Template

Find the south side wall of the house. Make sure it has full sun exposure and is free from the shade of trees and buildings, etc.

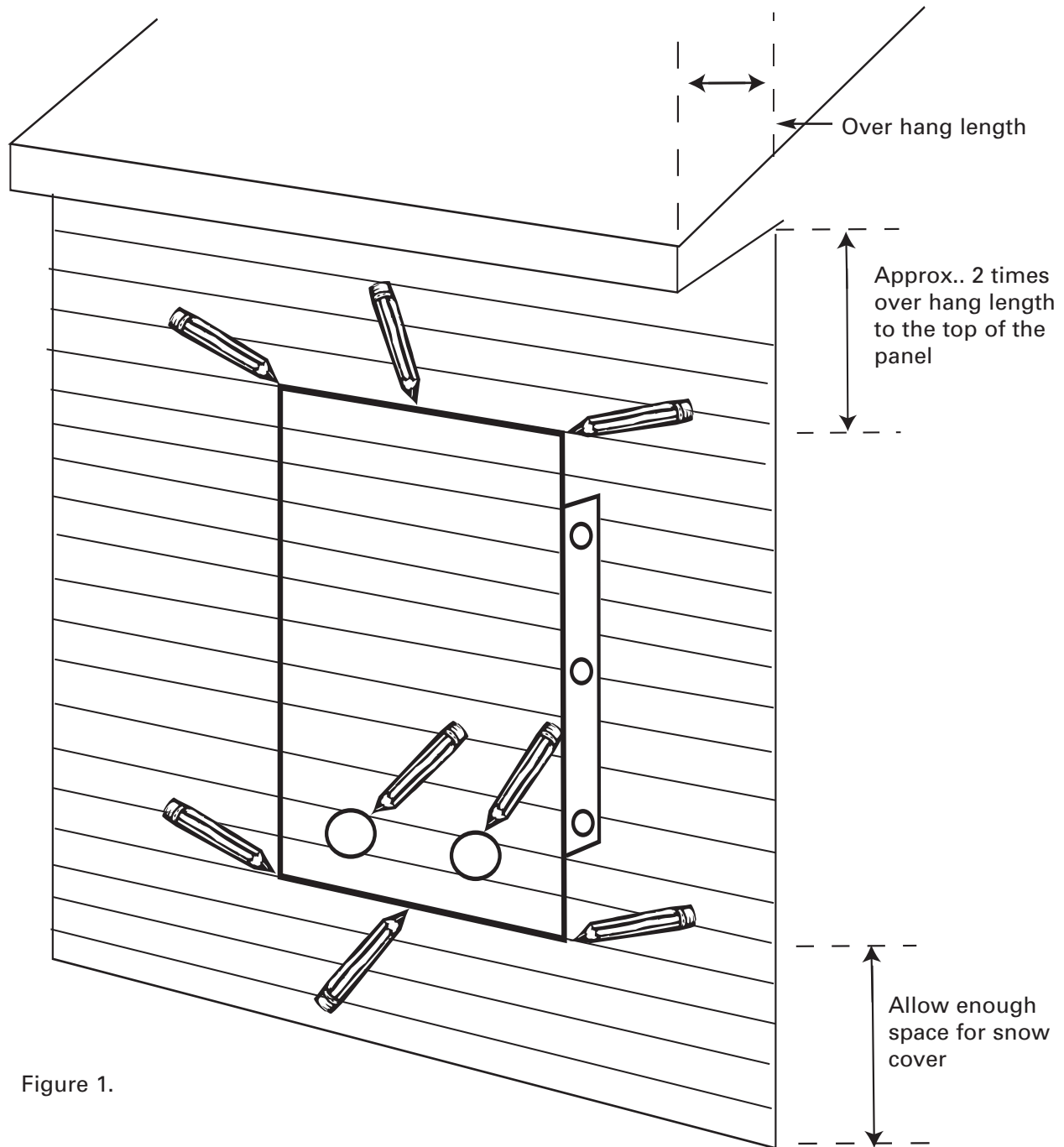

Figure 1.

1. Using the card board template supplied in kit, locate the desired height and location. Both on the exterior and interior of the house. Also locate the studs. **“WARNING”** Avoid GAS Piping/Electrical Wires and Plumbing. Using a level, make sure the template is plumbed or level. Temperately screw the template to the wall.
2. Mark the top and bottom of the template, both holes and a 1” mark on the 4 sides of the template.

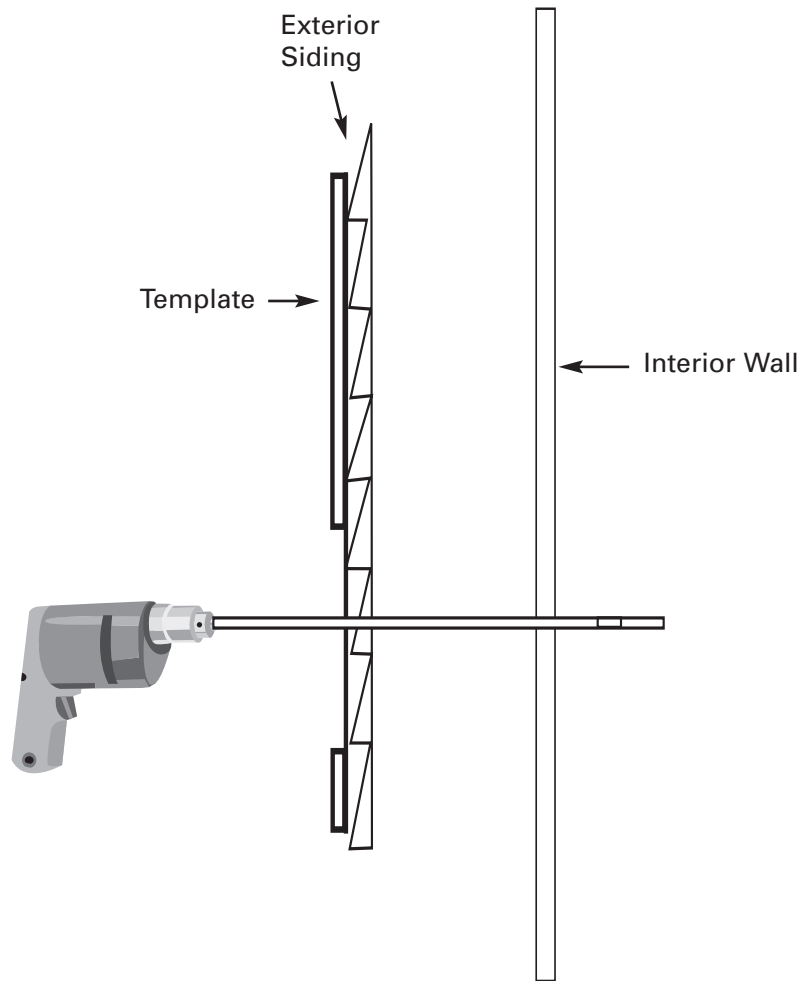

Figure 2.

3. Locate the center of the two holes on the template, using a drill and the pilot drill bit. Drill a pilot hole through the wall.

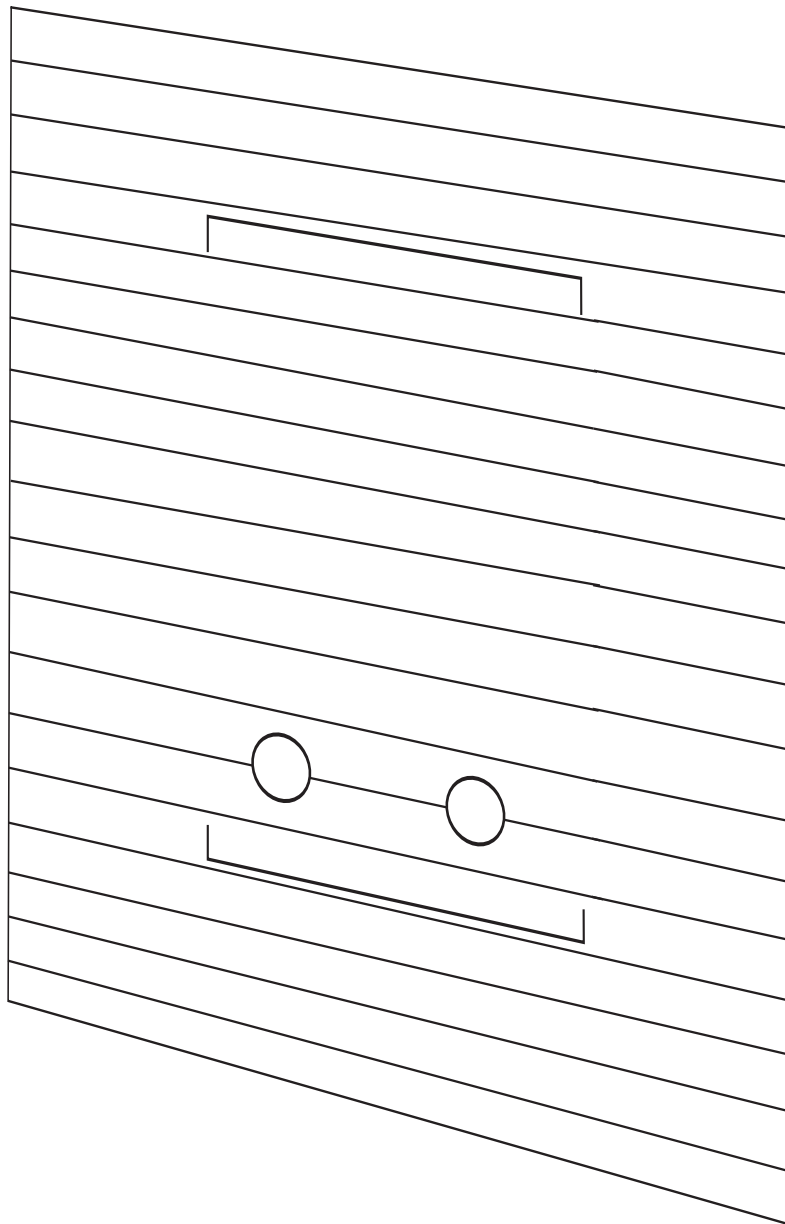

Figure 4.

4. Remove the template, using a 6 inch hole saw or jig saw, cut out two 6 inch holes through the exterior siding and sheathing. Move the insulation slightly making room for the return and supply vent.
5. Move to the inside of the house, locate both of the pilot holes that you drilled on step 3. Using a protractor, mark two 5-1/4 diameter holes. Using a key hole, saw cut-out the two 5-1/4 holes.

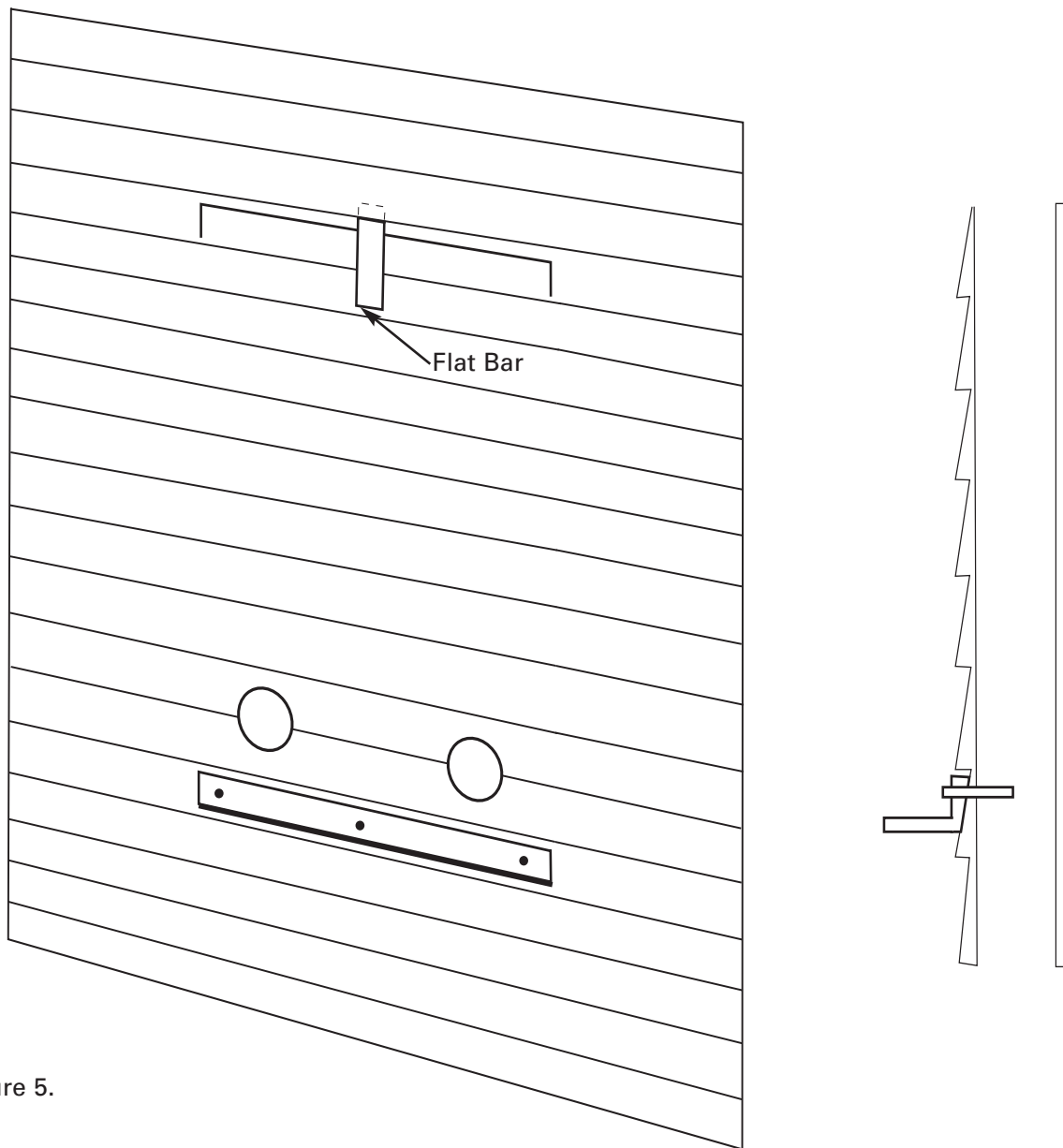

Figure 5.

Note: The predrilled holes in the bottom and top brackets are to fasten the solar panel.

6. Using the pencil marks you made on step 2. Using a level, level and drill holes in the bottom bracket where the studs of the wall are located. Screw bottom bracket into the studs of the wall.
7. Before mounting the top bracket use a flat bar and loosen the next piece of siding above the mark for the top bracket.

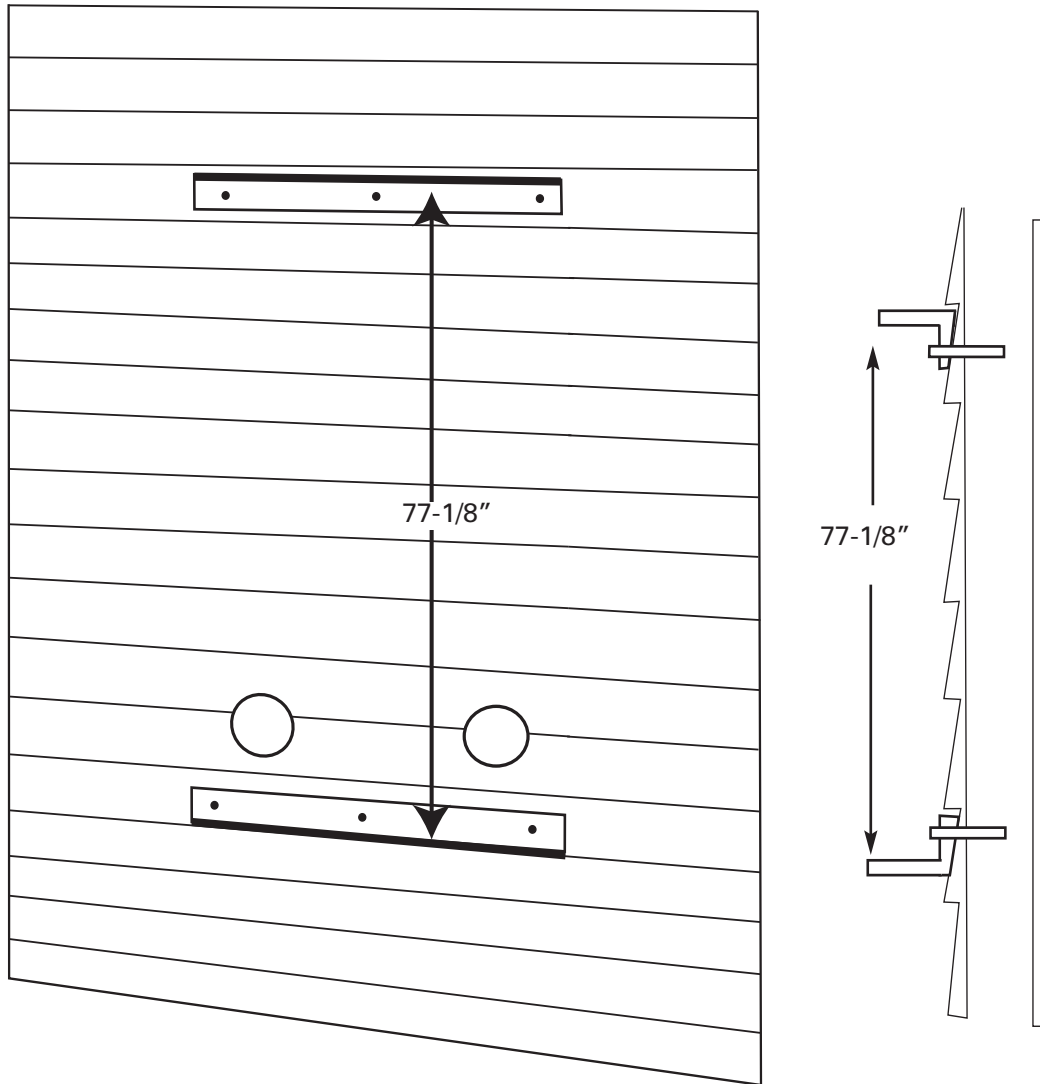

Figure 6.

8. Install the top bracket in-line with the mark on the wall making sure you measured 77-1/8 inches between the bracket flanges. Drill holes and screw the top bracket where the studs are located. Level and screw the top into the studs on the wall.

NOTE: The pre-drilled holes in the bottom and top brackets are for mounting the solar panel.

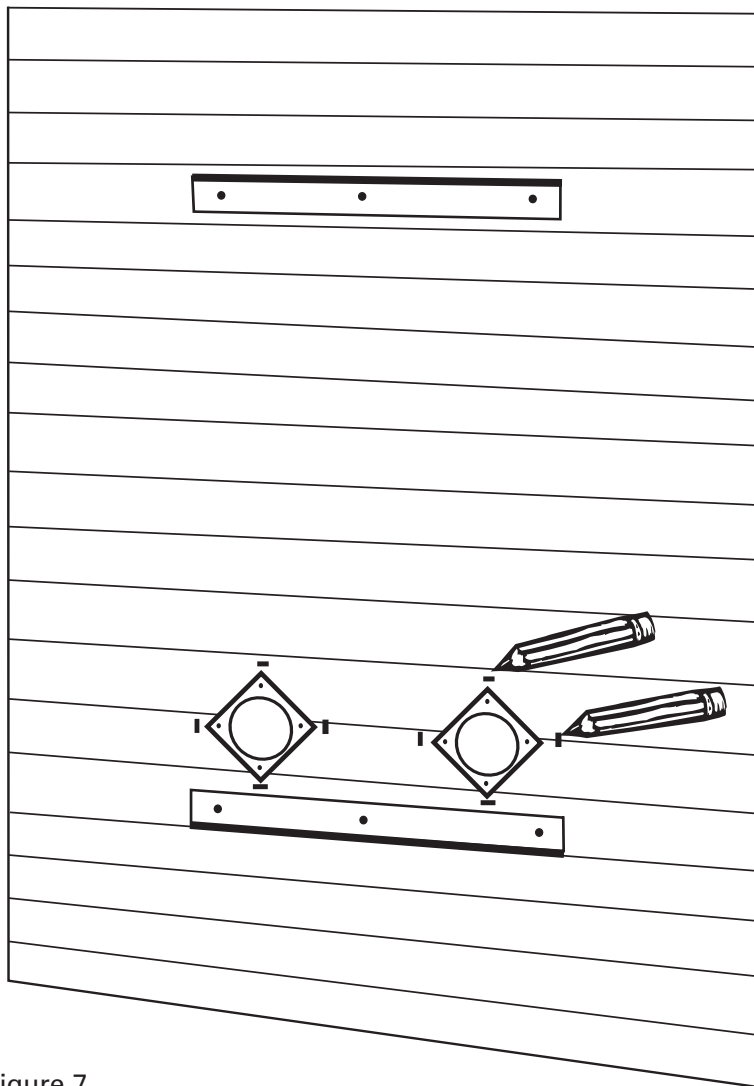
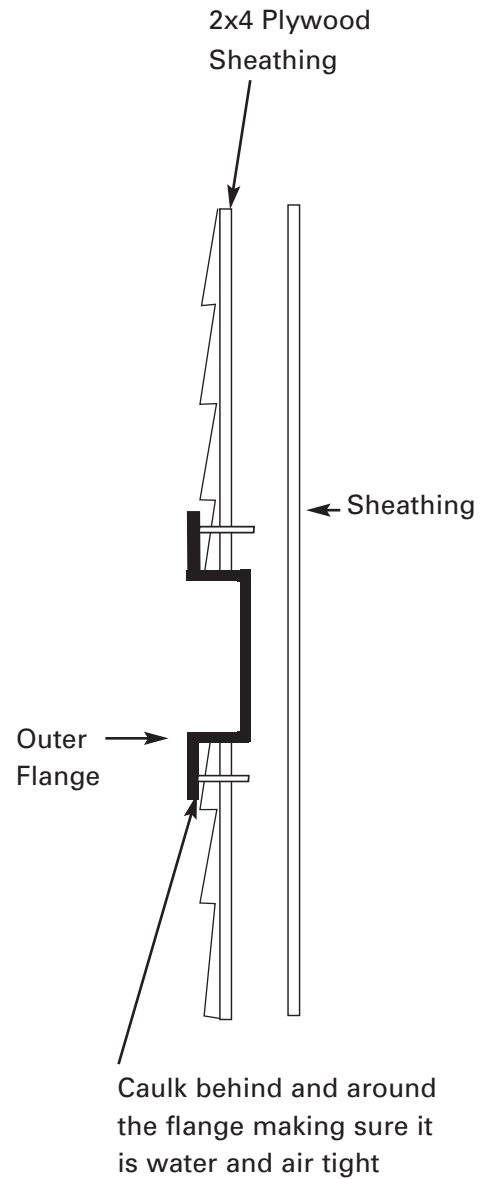

Figure 7.



9. Locate the outer flanges. Push the ring part of the flange into the wall. Push the flange side to side, up and down. Mark a small line on each Outer point of the flange. Remove the flange caulk and seal the flange making sure the outer flange is water and air tight. Locate the flange between the small screw marks you just made. Screw the outer flange into sheathing of the house.

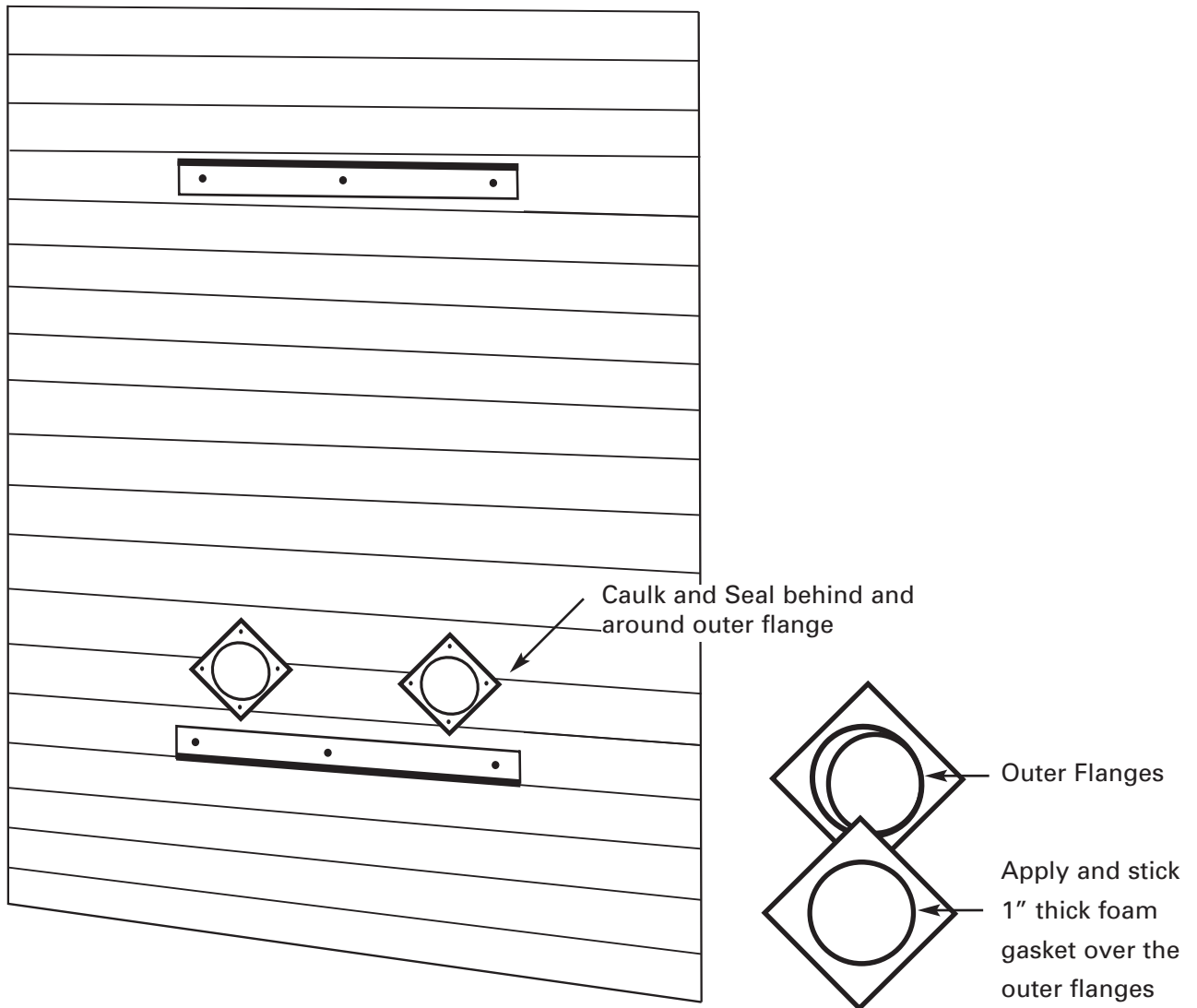

Figure 8..

10. Remove paper film from the back of the 1" foam gasket. Stick the 1" foam gasket over the outer flange

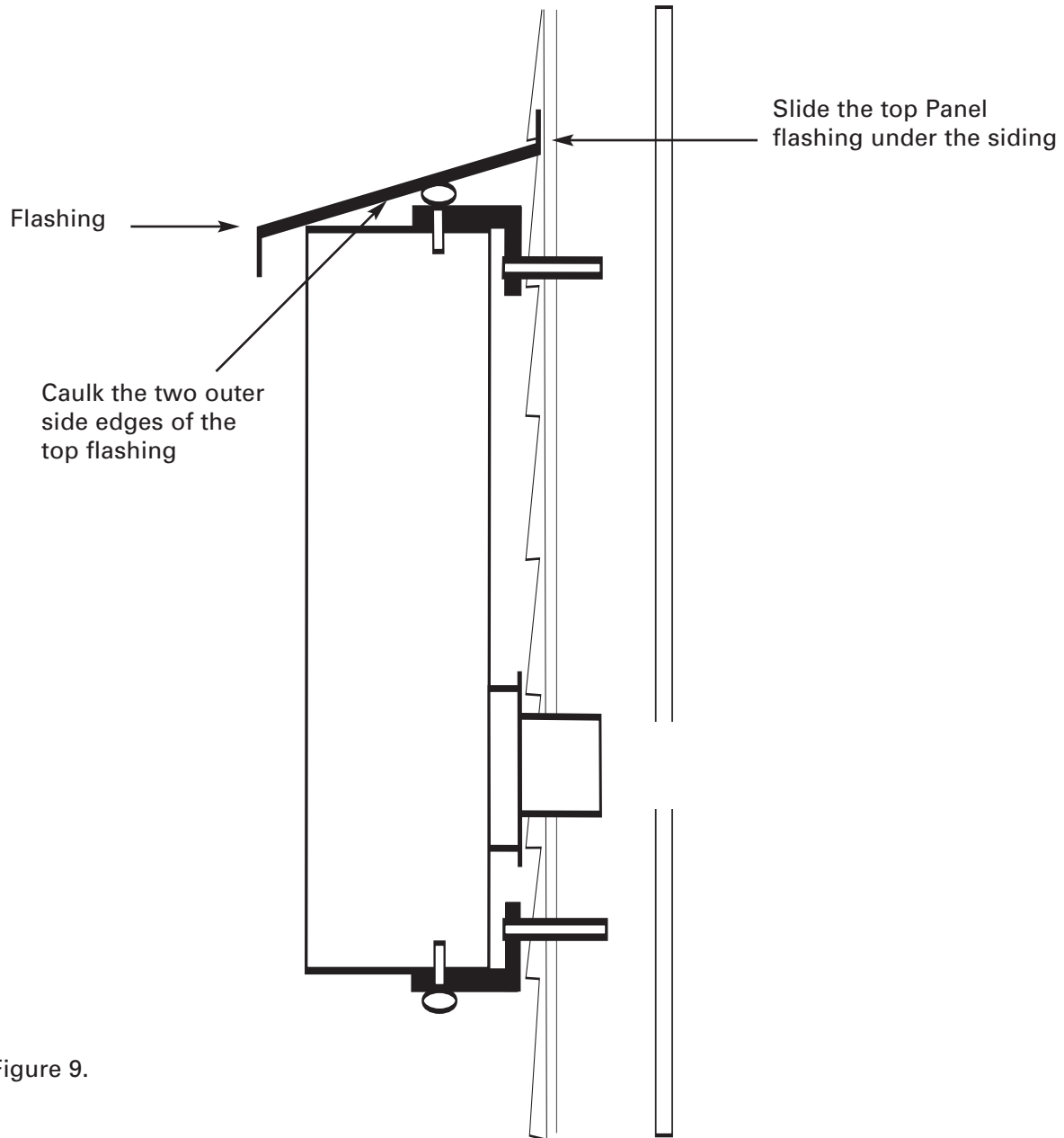

Figure 9.

11. Lift and position the SunMate Solar Panel between the bottom and top bracket. Using the 10 - 24 x 3/4 " long stainless steel screws, provided in the kit, screw the top and bottom of the solar panel (do not over tighten).
12. Slide the top panel flashing under the siding on top of the solar panel caulk outer side edges of the top flashing.

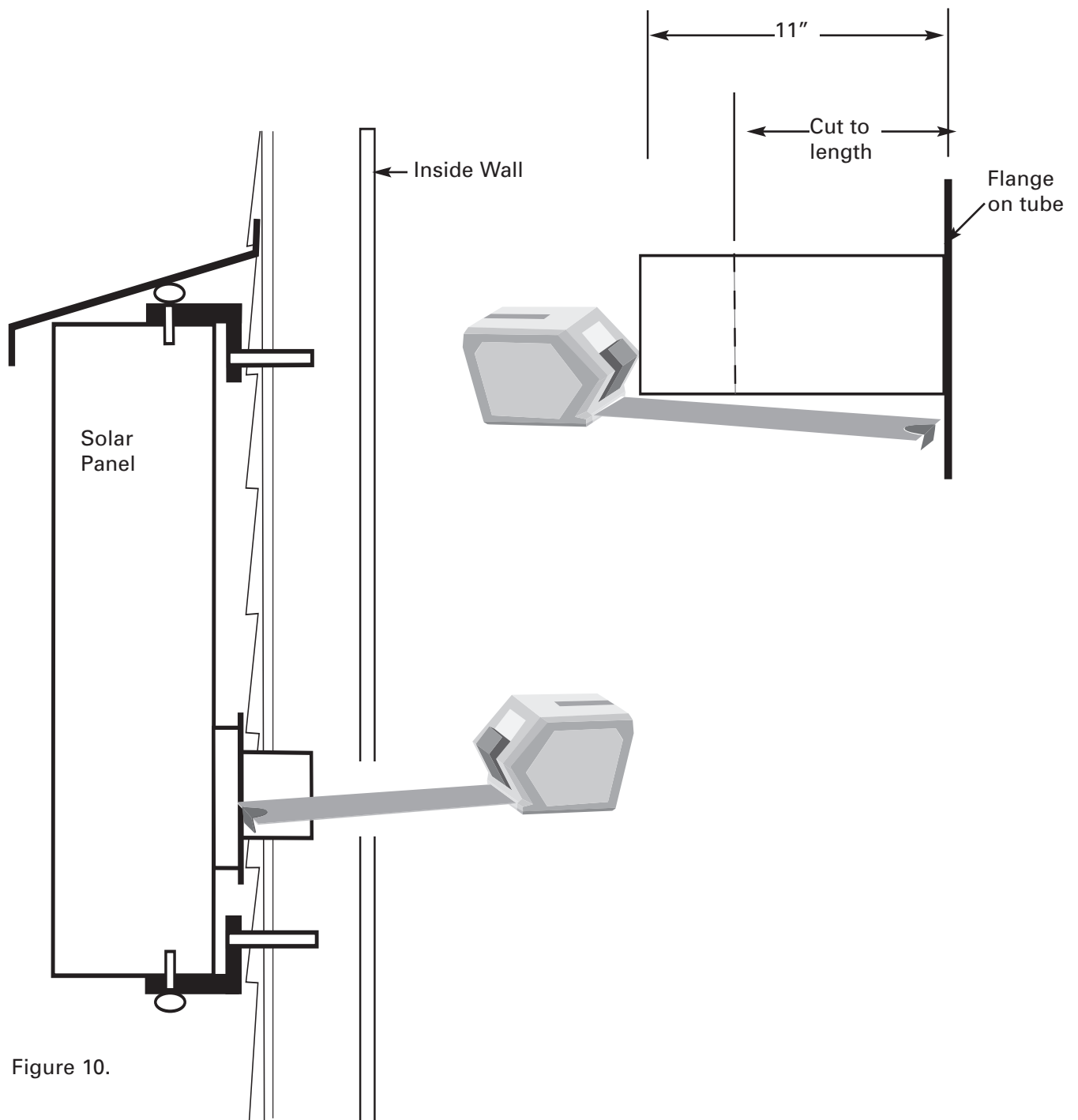

Figure 10.

13. Move to the inside of the house, using a tape measure, measure from the outer flange or plywood to the finish wall, subtract $1/4"$. Using that measurement, measure from the flange on the return and supply vent, mark and cut the tubes. Slip the tubes through the inside hole before screwing to the wall. Check to see if the flange seats properly against the finish wall. Screw the flanges to the wall. (For the fan side see step 14).

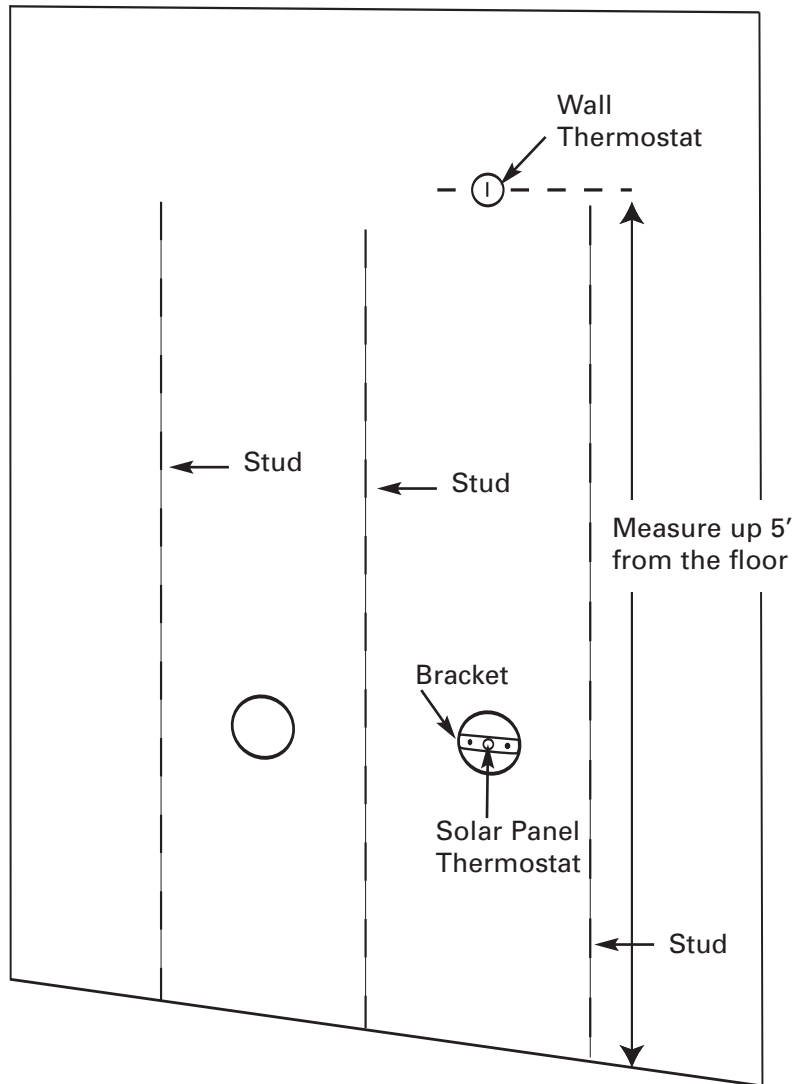

Figure 11.

14. Measure up 5 feet in the same bay as the fan is to be installed usually the right hole. Make a small 1/2" hole in the finish wall . 5 feet using an electric snake or stiff wire, run the snake down to the right hole. Attach 5 feet thermostat wire located on the fan tube, pull the snake until the thermostat wire comes through the 1/2" hole. Connect the red and white wire to terminals W an RH. It does not matter which wire goes to either terminal. Install the snap Disc switch inside the solar panel using the 8-32 SS nuts, provided in the kit. (Do not over tighten just tighten a touch more than finger tight. Connect the two female spade terminals/ The male spade terminals on the snap disc. (It does not matter what color wire goes where) Slip the tube through the hole making sure the red wire does not interfere with the fan blade. You may have to turn the tube a few times to coil the wire in the pipe. Screw the tube flange into the wall. Plug the energy star transformer into the jack.

Congratulations on installing your SunMate Solar Panel.