

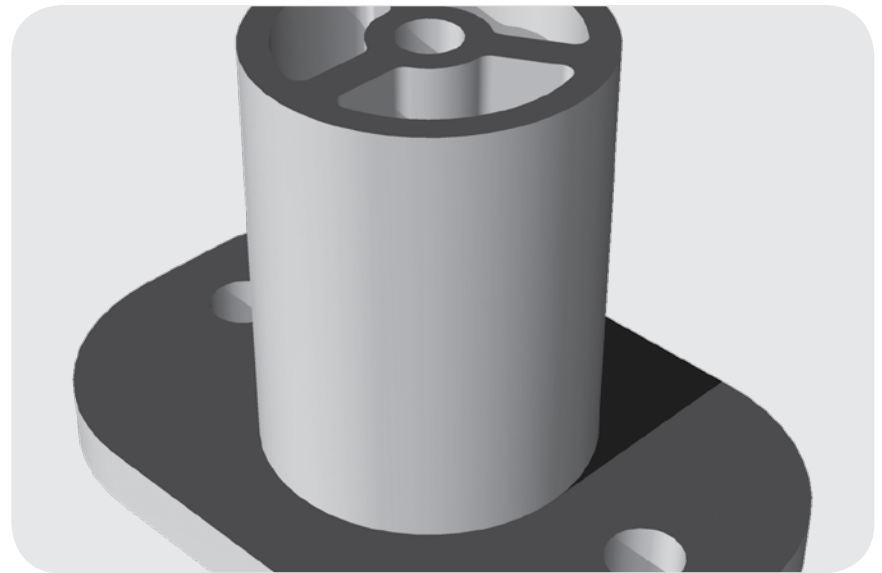

SolarMount-I™ INSTALLATION MANUAL

© 2010 by Unirac, Inc. All rights reserved.
Pub 101027-1ii, October 2010

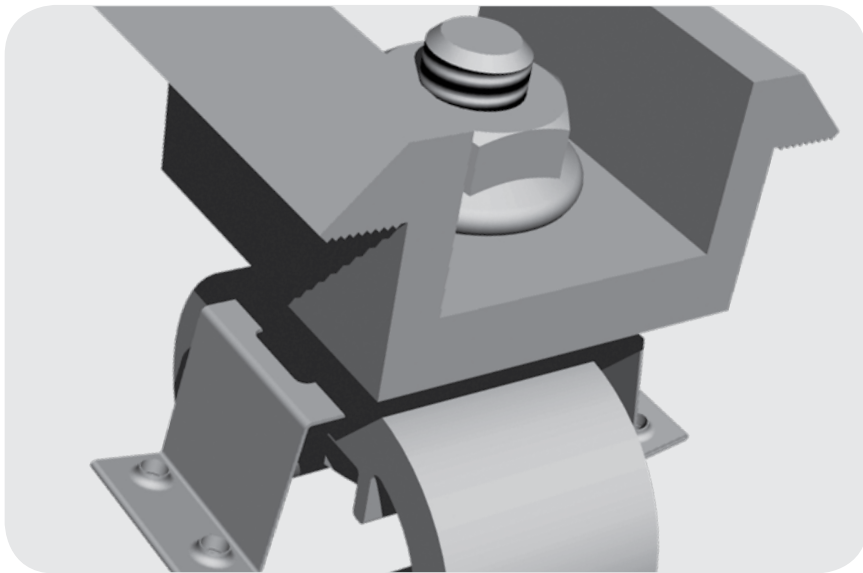

IMPORTANT!

Unirac Inc. makes no warranty of any kind with regard to this material, including, but not limited to, the implied warranties of merchantability and fitness for a particular purpose.

The information in this document is subject to change without notice.

Unirac shall not be liable for errors contained herein or for incidental or consequential damages in connection with the furnishing, performance, or use of this material.

This document contains proprietary information that is protected by copyright. All rights are reserved. No part of this document may be photocopied, reproduced, or translated to another language without the prior written consent of Unirac.

Unirac Inc.
Marketing Department
1411 Broadway Boulevard, NE
Albuquerque, NM 87102-1545

© Unirac Inc., 2009. All rights reserved.

SOLARMOUNT-I™ is a trademark of Unirac Inc. in the United States of America and other countries.

INTRODUCTION

SOLARMOUNT-I™

Thank you for choosing SolarMount-I™. This quick start guide provides easy step-by-step installation instructions. For additional information, please visit us at www.unirac.com.

BEFORE YOU BEGIN

- 1 Verify that all of the components are included and consistent with your order.
- 2 To avoid conflicts, never modify or combine Unirac's SolarMount-I™ with components that are not made for SolarMount-I. Doing so will void any warranty associated with SolarMount-I.

COMPONENTS



Beam

SolarMount-I 1.0 Beam = 1.094" Height
144" Length
SolarMount-I 2.5 Beam = 2.5" Height
144" and 192" Lengths



2 Flange Connection *

Shown without butyl option
(2) #14 X 3" Concealor™ screws
(1) 2 Flange Connector



1 Flange Connection

(1) 5/16" x 3-1/2" Zinc Plated Lag Bolt
(1) Stainless steel washer
(1) 1 Flange Connector



Beam Splice **

Shown without grounding option
(2) Stainless steel hex bolt
(2) Stainless steel flange nut
(1) Beam Splice

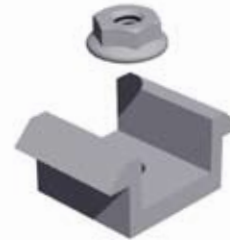

Mid Clamp

(1) Stainless steel hex bolt
(1) Stainless steel flange nut
(1) Slider
(1) Mid Clamp



End Clamp

(1) Stainless steel hex bolt
(1) Stainless steel flange nut
(1) Slider
(1) End Clamp



UGC-2 Grounding

* Butyl (optional with 2 Flange Connection)

** WEEB 9.5 Grounding (optional with Grounding Splice Kit)

OPTIONAL ATTACHMENTS



2-Piece Aluminum Standoff

- (2) 5/16" x 3-1/2" Zinc Plated Lag Bolt
- (1) 1 Flange Connection
- (1) 3/8" x 3/4" Hex Head Bolt
- (1) 3/8" x 1-3/4" EPDM Washer



CreoTecc Tile Hook (Top)

- (2) 5/16" x 3-1/2" Zinc Plated Lag Bolt
- (1) 3/8-16 x 3/4" Hex Head Bolt
- (1) 3/8" Hex Head Nut



PV Quick Mount

- (1) 5/16" x 3-1/2" Stainless Steel Lag Bolt
- (1) 5/16" Sealing Washer
- (1) 5/16" EPDM Washer
- (1) 1 Flange Connection

PLANNING YOUR SOLARMOUNT-I™ INSTALLATION

The installation can be laid out with beams parallel to the rafters or perpendicular to the rafters. Note that SolarMount-I™ Beams make excellent straight edges for doing layouts.

Center the installation area over the structural members as much as possible.

Leave enough room to safely move around the array during installation. Some building codes require minimum clearances around such installations, and the user should be directed to also check 'The Code'.

The width of the installation area equals the length of one module.

The length of the installation area is equal to:

- The total width of the modules,
- Plus 1 inch for each space between modules (for mid-clamp),
- Plus 3 inches (1½ inches for each pair of end clamps).

To speed installation, mark beam at approximate proper foot space before clicking connections to beam.

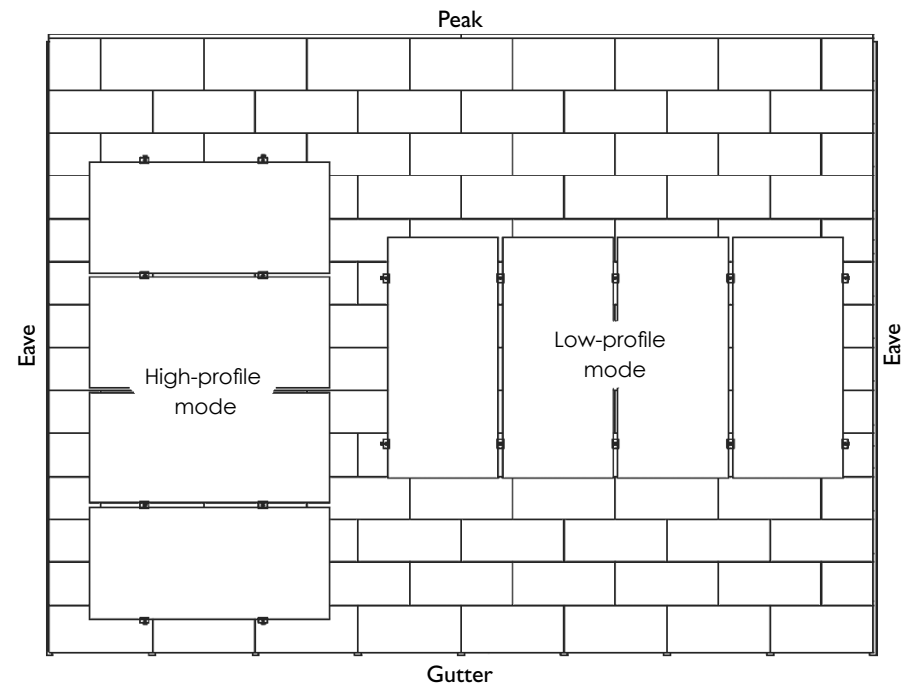

NOTE: Most installations do not overhang on attachment more than 18" of beam.

INSTALLING SOLARMOUNT-I™

Step 1: Attach beam to 2 Flange Connection or 1 Flange Connection

⚠ **NOTE:** Always engage the double-wall side before clicking connection into beam.

NOTE: Do not use connection if the engagement features on the connection are bent, damaged, or obstructed by debris.

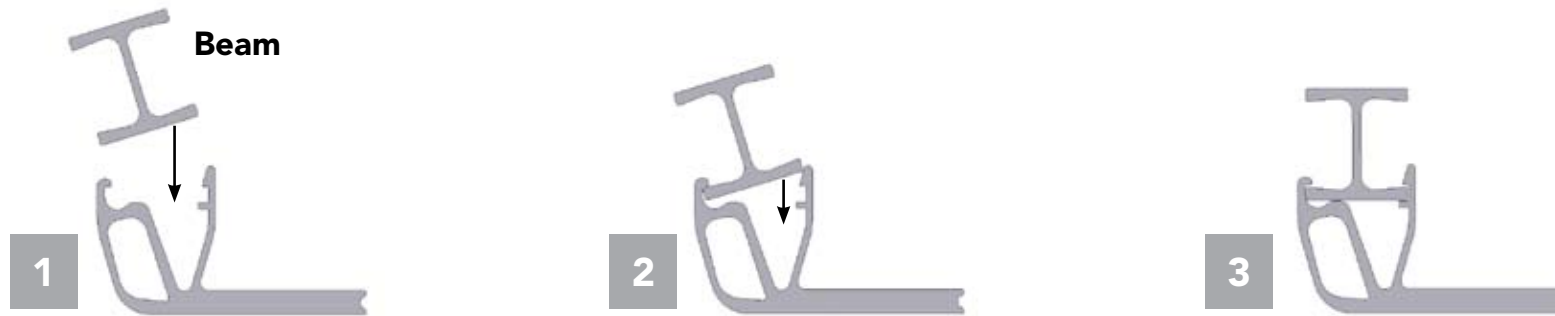

⚠ **NOTE:** When installing on pitched roof configurations, locate double-wall section of connection on the downhill side of roof slope.

⚠ **NOTE:** DO NOT re-use flange connections.

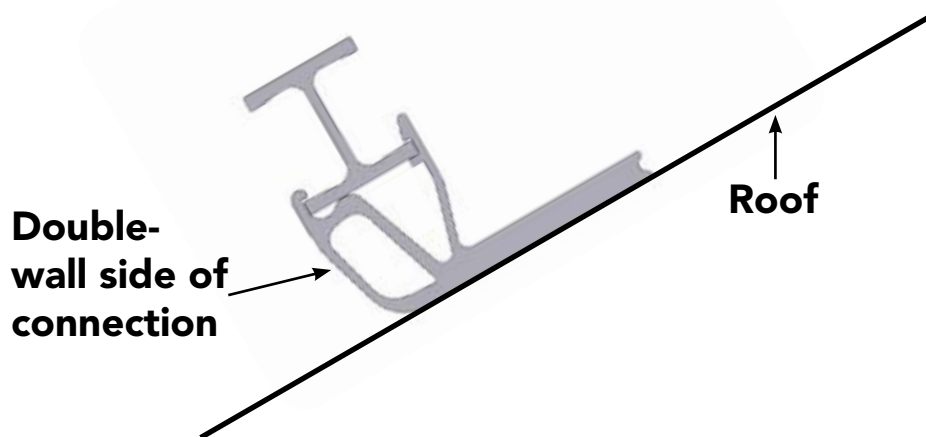

Step 2: Attach 2 Flange Connection or 1 Flange Connection to rafter

⚠ NOTE: When using 2 Flange Connection w/Butyl Pad, remove liner before installing screws.

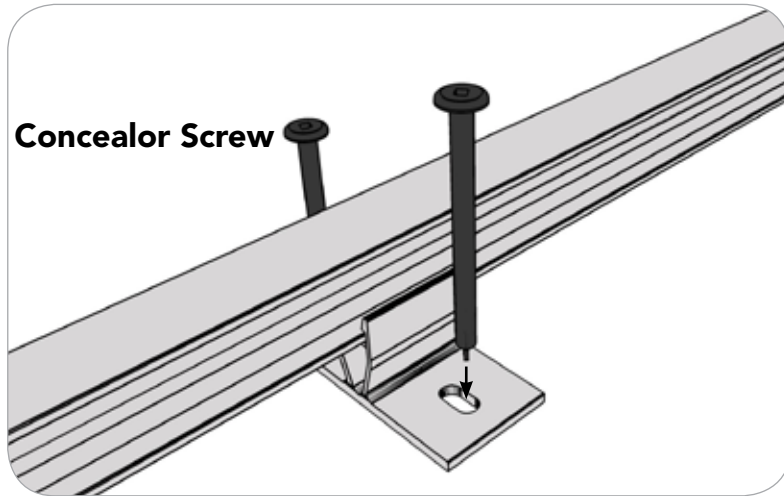

2 Flange Connection Option

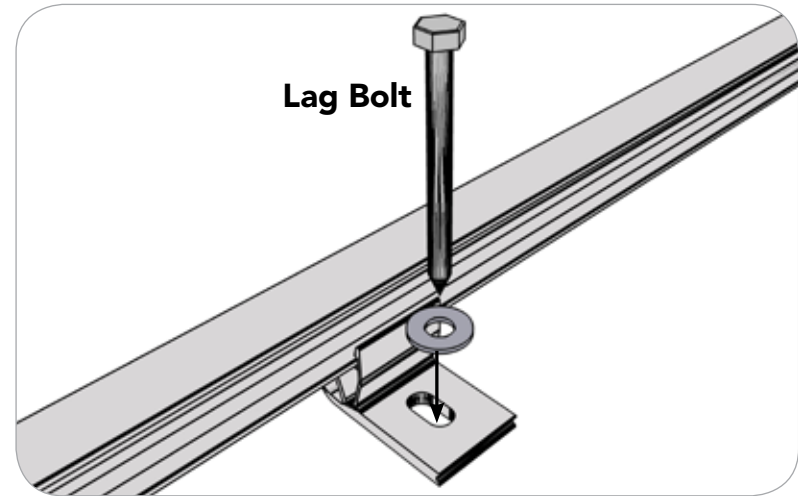

1 Flange Connection Option

Step 3: Install appropriate number of sliders and optional UGC-2 grounding clips

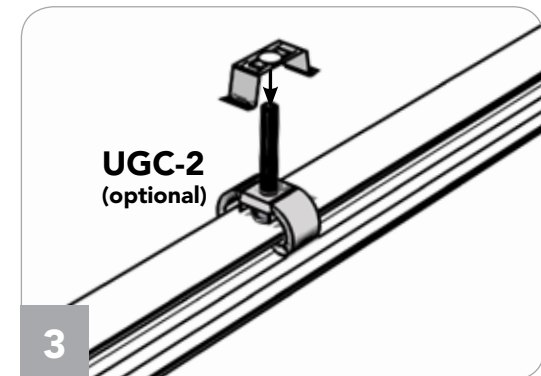
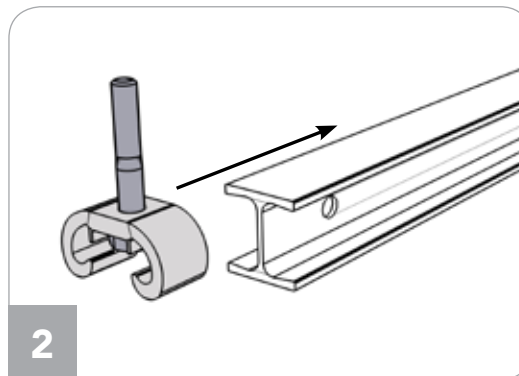
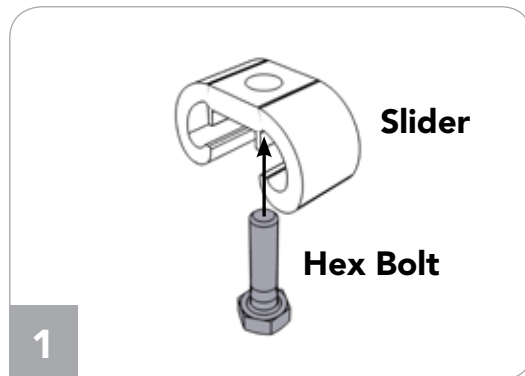

Step 4A: Install Splices (1) - Use when splicing two beams at a connection.

⚠ **NOTE:** Use anti-seize on bolt and tighten nut to 10 foot-pounds.

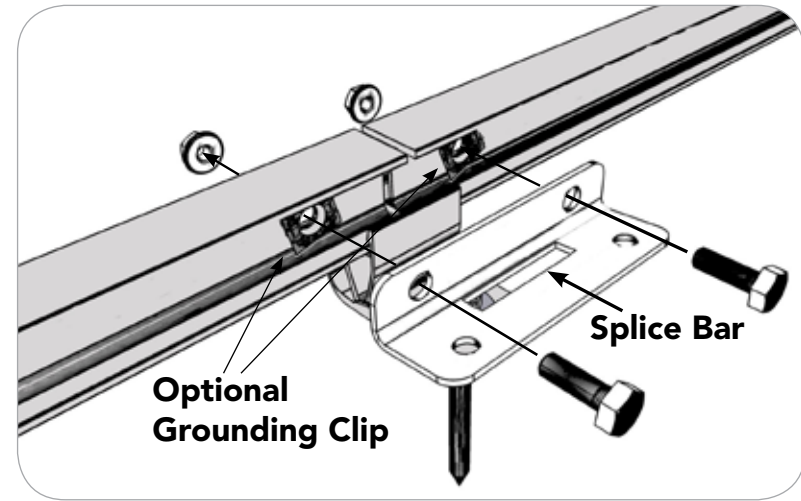
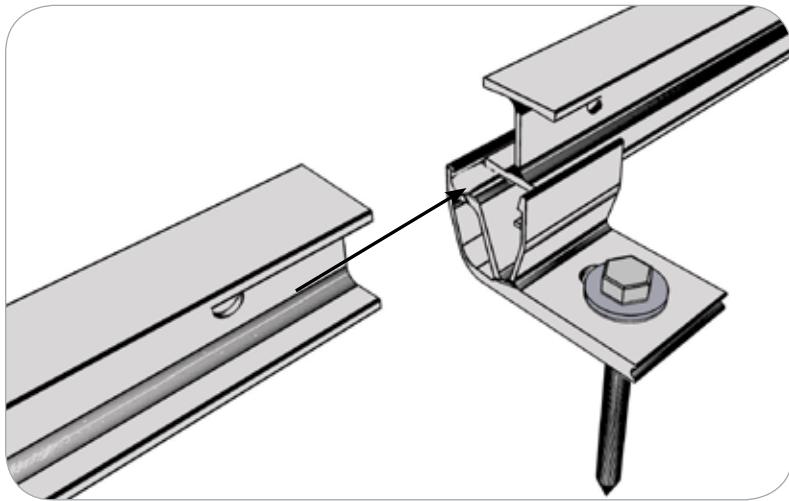

Step 4B: Install Splices (2) - Place at least one splice to act as a retaining clip over a flange connection for every run of beam. This may require field drilling.

⚠ **NOTE:** Tighten nut to 10 foot pounds with anti-seize

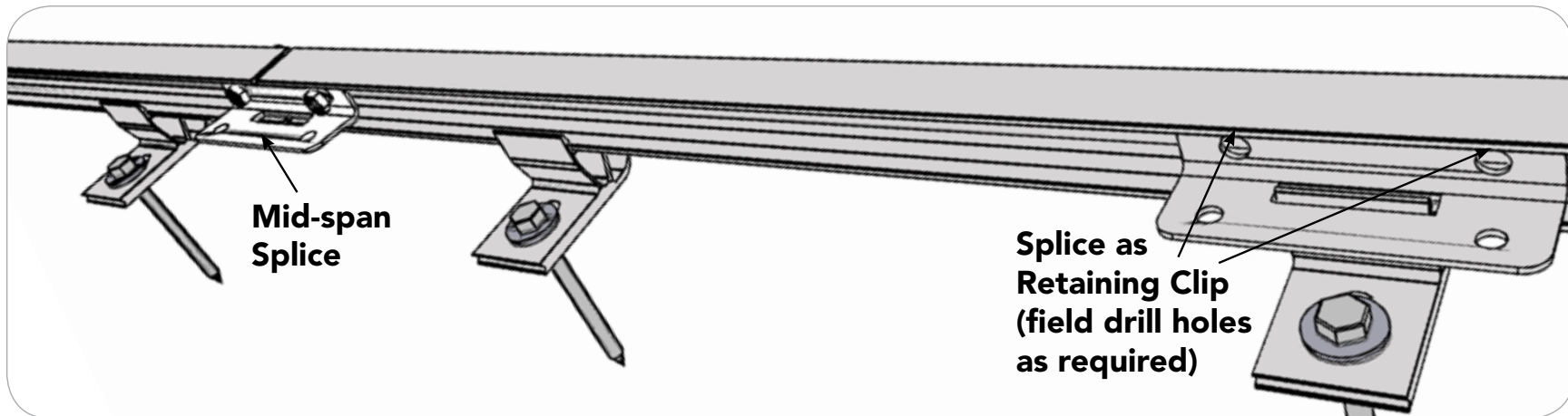

⚠ **NOTES ON THERMAL EXPANSION:**

SOLARMOUNT-I is designed to minimize the effects of thermal expansion by allowing the beams to expand and contract independently between connections and attachments. To minimize the effect of thermal expansion, restrict continuous beam lengths to 36 feet or three standard beam lengths.

⚠ **NOTE ON SPLICES:**

Please refer to technical datasheets for recommended distances between splices.

Step 5: Installing Grounding Lugs

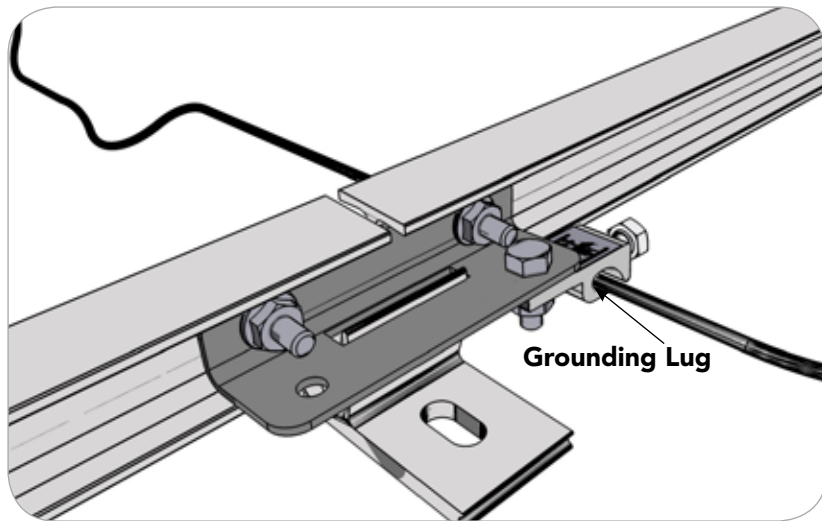

Step 6: Install modules using top mounting hardware

⚠ NOTE: Use anti-seize on bolt and tighten nut to 10 foot-pounds.

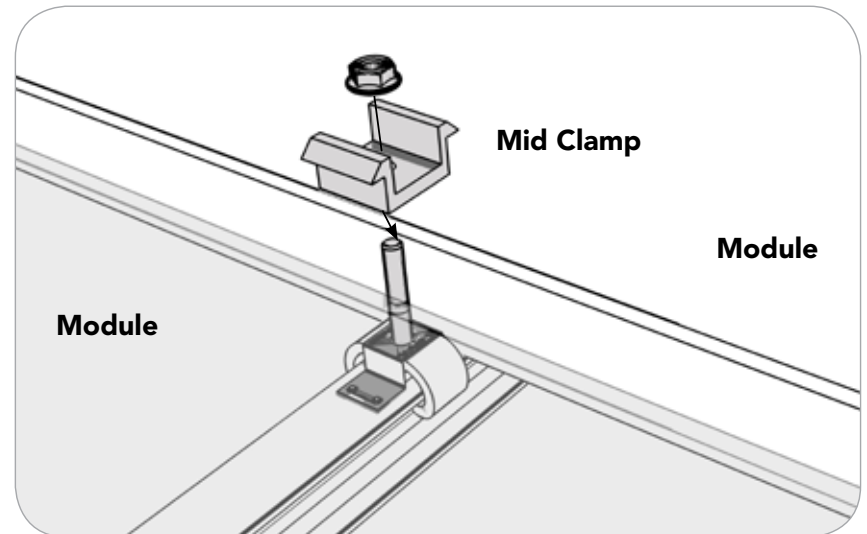
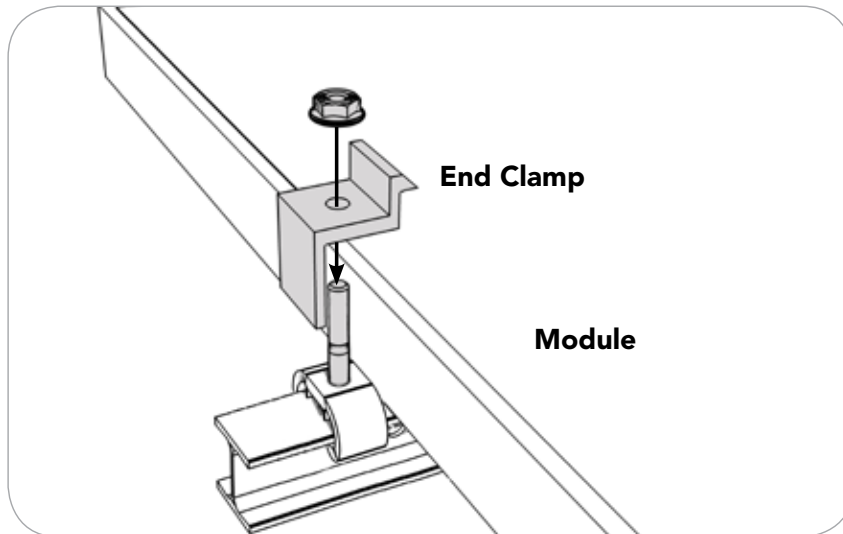

WARRANTY

10 year limited Product Warranty

Unirac, Inc., warrants to the original purchaser ("Purchaser") of product(s) that it manufactures ("Product") at the original installation site that the Product shall be free from defects in material and workmanship for a period of ten (10) years, from the earlier of 1) the date the installation of the Product is completed, or 2) 30 days after the purchase of the Product by the original Purchaser.

The Warranty does not apply to any foreign residue deposited on the finish. All installations in corrosive atmospheric conditions are excluded. This Warranty does not cover damage to the Product that occurs during its shipment, storage, or installation.

This Warranty shall be VOID if installation of the Product is not performed in accordance with Unirac's written installation instructions and design specifications therein, or if the Product has been modified, repaired, or reworked in a manner not previously authorized by Unirac IN WRITING, or if the Product is installed in an environment for which it was not designed. Unirac shall not be liable for consequential, contingent or incidental damages arising out of the use of the Product by Purchaser under any circumstances.

If within the specified Warranty period the Product shall be reasonably proven to be

defective, then Unirac shall repair or replace the defective Product, or any part thereof, in Unirac's sole discretion. Such repair or replacement shall completely satisfy and discharge all of Unirac's liability with respect to this limited Warranty. Under no circumstances shall Unirac be liable for special, indirect or consequential damages arising out of or related to use by Purchaser of the Product.

Manufacturers of related items, such as PV modules and flashings, may provide written warranties of their own. Unirac's limited Warranty covers only its Product, and not any related items.

SolarMount-I™ INSTALLATION MANUAL

www.unirac.com