

GUYED 70 FOOT TOWER KIT
for SKYSTREAM® and WHISPER 500 WIND GENERATORS

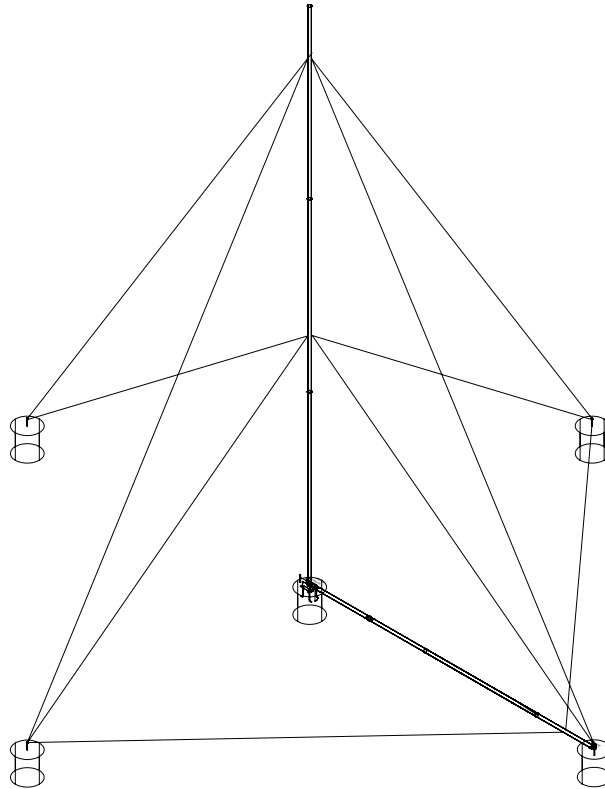

Made in the USA by:
SOUTHWEST WINDPOWER, INC.
1801 West Route 66
Flagstaff, AZ 86 001
(928) 779-9463

Please read **this manual thoroughly before beginning assembly**. If you have any questions on proper installation or usage please call either Southwest Windpower or your dealer for more information.

TABLE OF CONTENTS

CONTENTS	Page
TABLE OF CONTENTS	2
Introduction	3
Safe Installation	4
Tower Kit Parts List.....	5
Unpacking, Inspection and Approval.....	7
Step 1:Site Selection.....	8
Step 2:Mast Pipe and Hardware Selection	8
Step 3:Tower, Base and Anchor Layout	13
Step 4:Tower Base & Guy Wire Anchor Assembly	21
Step 5:Assembly of Pipe sections.....	22
Step 6:Attaching Guy Wires	23
Step 7:Grounding the Tower.....	27
Step 8:Raising the Tower.....	27

Introduction

This guyed tower kit is designed specifically for the Southwest Windpower Skystream 3.7® and Whisper 500 wind turbine. To our knowledge this is the most economical and user-friendly tower kit available for the Skystream 3.7® and Whisper 500 wind turbine. The tower kits are designed to use guy wires, allowing the use of 5" schedule 40 pipe while providing adequate strength, even in high wind conditions. At least two people should be present to safely raise the tower.

Carefully read and understand the disclaimer at the beginning. While simple in concept these towers require basic mechanical aptitude and attention to detail. Read the system planning section of the Owners Manual and determine the location for the tower. It is much easier to work with nearly level ground. Parts listed to construct these towers are readily available in most parts of the world.

Thank you for purchasing our products and for your interest in renewable energy. We expect that you will enjoy the benefits of your wind powered electrical system for many years to come. If, after reading this manual, you have any further questions please contact your local dealer or Southwest Windpower and we will do our best to assist you.

NOTE:

**Skystream 3.7® Tower Adaptor is not included in this kit.
Please purchase separately.
PART # 2-TWS-100**

Safe Installation

Safety is the most important consideration to take into account when installing a tower and wind turbine. It is very important to remember that any wind turbine has high speed spinning parts and can be very dangerous if not installed properly! Make sure that the Schedule 40 steel pipe used for the tower is of adequate strength, that all bolted connections are tight and the guy wire anchors are suitable for your soil conditions. All of these elements are explained in further detail later in this manual. **Important! Choose a very calm day to do your installation. A gust of wind at the wrong moment could cause A VERY SERIOUS ACCIDENT!**

PLEASE...READ ALL OF THIS MANUAL BEFORE DOING ANYTHING !

Tower Kit Parts List
WTO-GP3-20K8 (70 Ft/ 21m)

Your tower kit includes:

QUANTITY	PART No.	PART DESCRIPTION
2	3-CMBP-1334	BASE PLATE
4	3-CMBP-1268-01	GUY TAB-PUNCHED (30°) (3 Holes - For Tower)
4	3-CMBP-1268-03	GUY TAB-PUNCHED (45°) (3 Holes - For Tower)
2	3-CMBP-1268-02	GUY TAB-PUNCHED (45°) (2 Holes - For Gin-Pole)
1	3-CMBP-1267	LINK—GIN POLE TO 2 TURNBUCKLES
2	3-CMBP-1266	LINK—GIN POLE TO ANCHOR EYEBOLT
9	3-HDBT-1005-407	SIDE GUY TAB BOLT -- 5/8 - 11 X 7 1/2" GR5 ZINC
3	3-HDBT-1005-408	HEX HEAD BOLT--7/8-9 X 8 GR 5 ZINC
1	3-HDBT-1005-395	HEX HEAD BOLT -- 7/8-9 X 3 GR 5 ZINC
9	3-HDNT-103-21	NYLOCK HEX NUT--5/8-11 GR 5 ZINC
4	3-HDNT-103-25	NYLOCK HEX NUT--7/8-9 GR 5 ZINC
4	3-HDBT-9002	ANCHOR BOLT FOR BASE ANGLES--3/4 X 18 GALVANIZED
4	3-HDWA-103-15	3/4" SPLIT LOCK WASHER FOR BASE ANCHOR BOLTS
20	3-CAOT-1208-06	THIMBLE --5/16 HEAVY DUTY
68	3-CAOT-1209-05	WIRE ROPE CLIP --5/16 DROP FORGED STEEL
8	3-CAOT-1102	TURNBUCKLE -- 5/8 X 9 EYE & AJW DROP FORGED
700	3-CAOT-1207-08	GUY WIRE--5/16"
2	3-CMBP-1269	TUBE SPACER FOR BASE ANGLE LOCATION
12	3-CMBP-1323	TOWER COUPLER
108	3-HDBT-1020-246	1/2" - 13 X 1 1/2" CARRIAGE BOLT
108	3-HDNT-103-17	1/2" - 13 X 1 1/2" NUT
108	3-HDWA-106-12	1/2" FLAT WASHER
3	3-CAOT-1116	SHACKLE 3-1/4" TON, SIZE 5/8"

Items NOT Included in This Kit:

Description	Quantity
Tower Adaptor (2-TWS-100) (for Skystream 3.7 install only)	1
5" Schedule 40 Steel Pipe	5 x 21' (6.4m)
3/4" x 12 inch forged eyebolt for anchor	2
3/4" x 8 inch forged eyebolt for anchor	2
Copper ground rod	1
Grounding Wire	10 ft
Rope for tower lift line (8000 lbs min. breaking strength)	80 ft
Rope for gin pole lift line & ladder side support (4000 lbs min. breaking strength)	175 ft
Pulley for tower lift line (min. 4500 lbs rating)	1
Pulley for gin pole lift line (min. 3000 lbs rating)	1
10 ft ladder rated for 250lbs	1
Concrete (2500 psi rating)	4.5 yd ³ (0.9/anchor)

Rebar –various sizes and lengths.
Wood blocks, bricks to lift pipe 7” above ground level
Sledgehammer
Heavy duty ½” drill
leather gloves
Safety glasses
Grease to slide pipe inserts into place
Metal file to remove excess metal in pipe edges

See Anchor Details

IMPORTANT: Do not attempt to use lower quality rope. A standard knot on a rope will diminish its strength in half. For this tower kit we only recommend the ropes available at Adventure Gear or Bent Gate Mountaineering. These are mountain climbing ropes designed for higher strength than the ropes found at your hardware store. Do NOT attempt to install this tower kit using a lower quality rope.

Unpacking, Inspection and Approval

1. Inspect the parts included in your tower kit and make sure that nothing is missing or damaged. Use the *Parts List* for assistance identifying parts as you unpack your kit.
2. Parts NOT included in the Tower Kit must be procured locally, and should be available at a hardware store. Pipe for the tower can be purchased from a local plumbing or steel supplier. Use the list of suppliers recommended by Southwest Windpower for the for lift lines, pulleys, and anchor eyebolts.

Refer to the *Parts List* to determine the total length and number of pipes required for the tower itself and the lift pipe (ginpole). Make sure your materials supplier cuts the pipes to the appropriate length BEFORE you have them delivered to your site! The kit will require drilling holes on the pipe.

You also need to decide if you will be lifting the tower by vehicle or winch, and obtain the necessary equipment and components. An appropriately sized winch can be used instead of a vehicle and pulley system.

3. This tower kit has been reviewed for tower stress and anchor load analysis per the 1997 Uniform Building Code (UBC) for static analysis only. A registered professional engineer who is licensed to practice in the States of Nebraska and California did the analysis. For counties that require a building permit, request PE Stamped Engineering approved tower and foundation plans (Nebraska, California) from Southwest Windpower. Submit the engineer-approved tower and foundation plans to your local building permit authorities and obtain a building permit.
4. Before installation, clean, prime and paint all parts including the base angles furnished in the kit. In particularly corrosive environments you may wish to consider having parts hot-dipped galvanized. Hardware (nut, bolts, turnbuckles, guy wire, etc.) furnished by Southwest Windpower in the tower kits are galvanized for corrosion resistance.

Step 1: Site Selection

Site selection is the most important factor affecting the performance of your wind turbine!

The energy in the wind is the kinetic energy of the moving air mass. What a wind turbine does is convert some of that kinetic energy into mechanical energy, which is then converted to electricity. The formula for the amount of power in the wind is a cube function of the wind speed. This means basically that an increase in wind speed of 10% (say from 9 mph to 10 mph) will result in approximately a 37% increase in the energy available from the wind and a similar difference in turbine performance. In almost all locations the wind speed increases, as you get higher off the ground. This is why the taller the tower the better. As a rule, the turbine should be mounted as high in the air and as far away from obstructions as is possible.

To find the best location to erect your tower and wind turbine, study the area available and take note of how the prevailing (most common) winds blow through it. If there are trees, buildings, hills or other obstructions take note of how high they are and where they are in relation to the prevailing wind direction and your proposed tower location. The best site for your tower and turbine will be upwind and above any obstructions which may exist. If there are houses or trees in the surrounding area it is best to mount the turbine at least twice as high as any obstruction in the area. If the turbine is to be mounted at the crest of a hill or on a beach where winds come from across the water, a lower tower may be acceptable.

The next consideration in siting your tower and turbine is the distance from the turbine to your batteries. The shortest distance will require the least amount of wire and reduce the amount of power lost through the wiring. If a long distance is required between your tower and the batteries it will be necessary to use heavy gage wire to reduce the resistance of the wire. The power consumed by the wires can be calculated using the formula:

$$\text{Power} = \text{Current} \times \text{Current} \times \text{Resistance} (P=I^2R)$$

Since the resistance of the wire is directly proportional to its length, making the run shorter will dramatically reduce the amount of power "lost" in the wires. Refer to the Whisper Owner's manual and make sure you are using correct gage wiring to minimize system losses. The person laying out your power system should be aware of these considerations when the system is in the planning stages.

Step 2: Mast Pipe and Hardware Selection

Due to the high cost of shipping and the widespread availability of pipe used for the tower, Southwest Windpower does not provide these materials. Materials are readily available through most hardware stores or plumbing companies and will cost much less when purchased locally than if they were shipped from our factory.

The Skystream 3.7® (with tower adaptor) and Whisper 500 are designed to be mounted on a 5" inside diameter pipe (12.7 cm). The pipe is classified as 5" Schedule 40 steel pipe. Around the world pipe may come in different sizes. Make sure your pipe is Schedule 40 with a wall thickness of 0.258" (6.5 mm), and an external diameter of 5.563" (14.1 cm).

NOTE: *In some areas there are subsidies and grants available for installing renewable energy systems. If you live in one of these areas and need an engineering analysis for this tower*

assembly to satisfy your local authorities please contact us. We have an engineering analysis available for this tower kit.

Pipe Length Table for 5 inch Schedule 40 Pipe 70Ft(21m) Tower (See Figure 1)

No. Parts	Tower Part	Description	Length ft(meters)
1	Lift-Pipe (horiz.)	Pipe connected to Base	14ft (4.25m)
1	Lift-Pipe (horiz.)	Pipe connected to Anchor	21ft (6.4m)
1	Tower (vertical)	Pipe attached to Base	7ft (2.1m)
3	Tower (vertical)	All other pipes for Tower	21ft (6.4m)

Figure 1 describes the way the different pipe lengths are assembled.

GP3-21 (70ft)

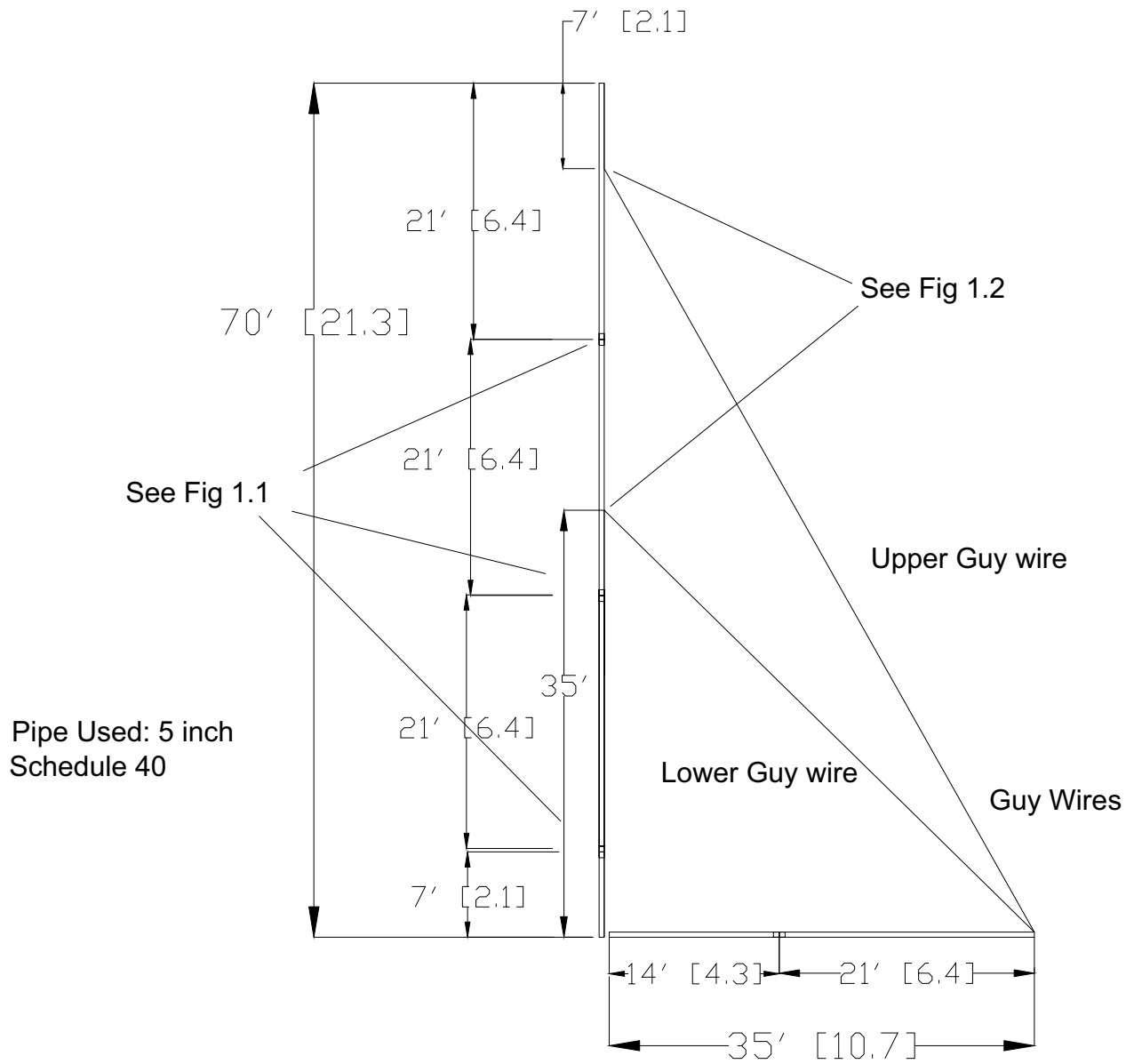
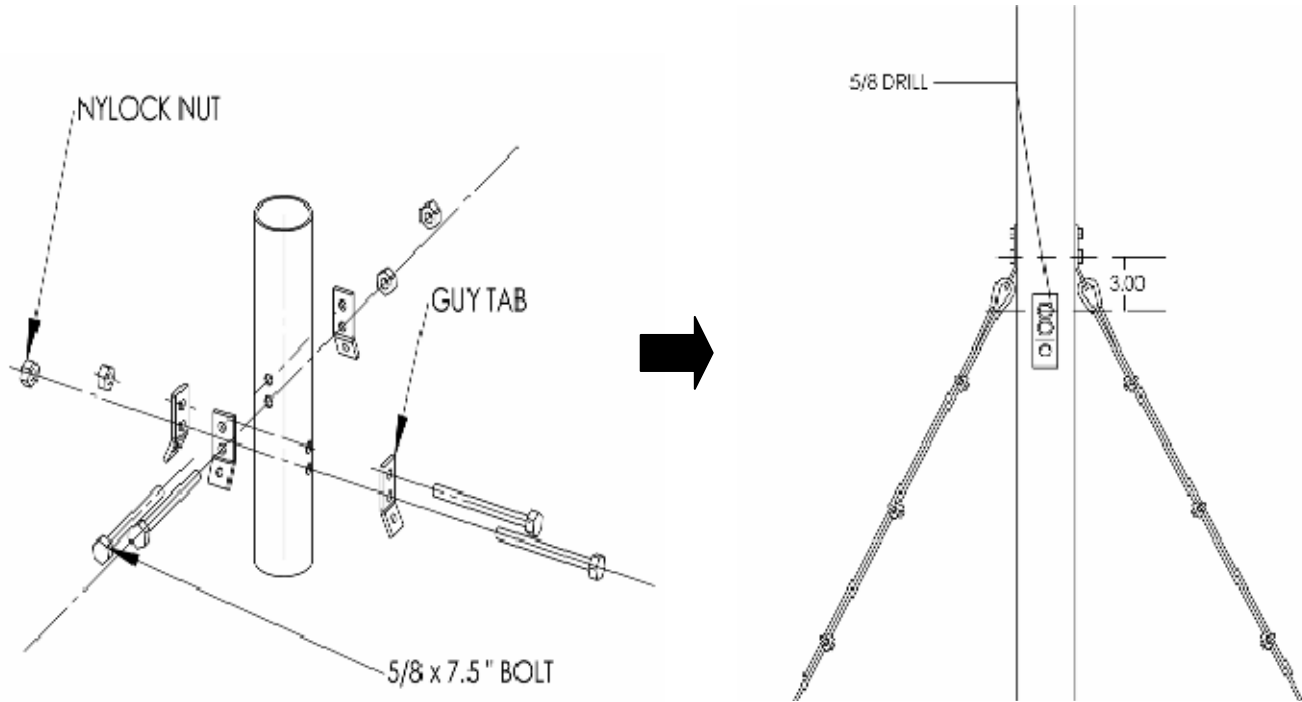

Figure 1: Tower Layout

Figure 1.2



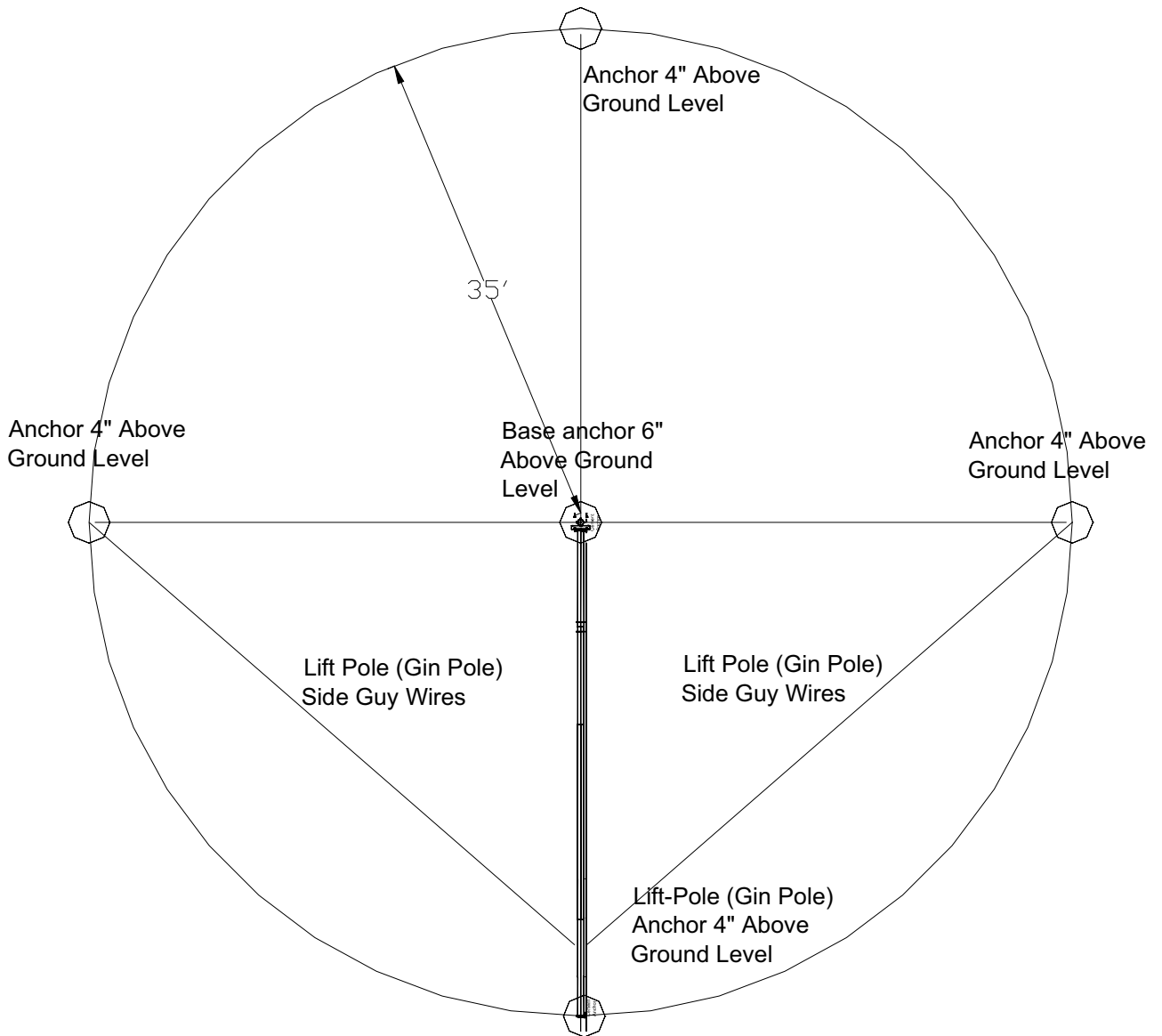

Figure 2: Birdseye View

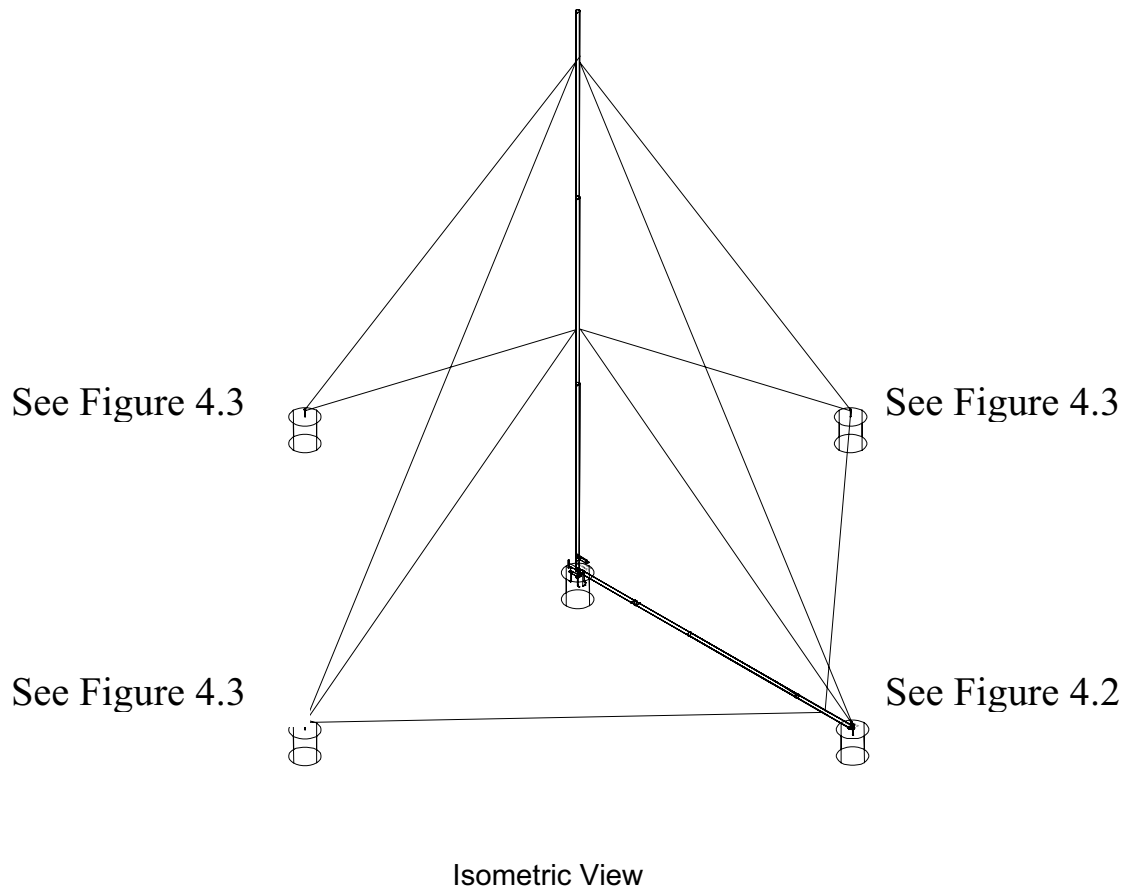

Figure 2: Anchor and cable layout

Step 3: Tower, Base and Anchor Layout

This tower kit must only be erected on a calm day (no wind). The tower base and anchors should be laid out as described in Figure 2 and Figure 7. The tower will be assembled laying on the ground and then tilted up into position.

IMPORTANT!

Carefully study *Figure 2 and Figure 7* to help you determine how much space you will need to raise your tower, which is pulled up from the lift anchor. Be especially aware that the concrete anchors are 4 inches above ground level. The lift anchor is slightly off-center (3-4 inches) in order to be assembled with the metal links. Keep both things in mind while you dig and

If the tower is being erected on the side of a hill it will be much easier to raise the tower if it is assembled to the uphill side of the base, as it will already be part way up once it is assembled. In this case the two opposing anchors should be at the same height on the hill as the tower base, one anchor should be directly uphill and one directly downhill from the tower base. The ground must be level or made level between the side anchors and the tower base. The ground may slope steadily downward from the tower top (when it is in the lowered position) to the tower base, and from the tower base to the lift anchor. When the lift anchor lies lower than the tower base there is more room for winches, lifting pulleys, etc.

Be sure the anchor points and base position are in a line when sighted from anchor to anchor. It is very important that the center of the eyebolts on the side anchors are in line with the center pivot bolthole on the base angles. This means that the center of the eyebolts on the side anchors should be 6 inches above the top of the 4-inch concrete anchors for a total distance of 10 inches above the ground (see Figure 4.3). This must correspond with a base anchor that is 6 inches above ground level because the hole in the angles is 4 inches above the concrete for a total distance of 10 inches above ground (see Figure 2). This will ensure that the forces on the guy wires are balanced properly, make final guy wire adjustments simpler and will help a great deal during the actual raising of the tower. The side anchors and tower base should also be at the same height. If either of these requirements are not met, **the guy wires will either tighten excessively or become excessively slack as the tower is raised. If the guy wires tighten excessively the tower may buckle and collapse, causing possible injury or even death and at the very least, damage to both the tower and the turbine. Carefully read the section on raising the tower for further instructions on making the proper adjustments in these situations.**

A tower should never be close to occupied buildings. A good rule of thumb is to select a location that is a distance of at least one and a half times the tower height. Thus, if you are installing a 70' (21m) tower, the tower should be a distance of at least 105 feet (30 m) from any occupied buildings.

CAUTION!
NEVER INSTALL A TOWER WHERE IT COULD CONTACT
POWERLINES IN ANY DIRECTION.
DANGER OF LETHAL SHOCK!
CONTACT WITH OVERHEAD POWER LINES WILL CAUSE INSTANT
ELECTROCUTION

These towers may often be set in wooded areas. It is only necessary to clear enough trees for the guy wires. Clear the path for the guy wires as the tower is raised and lowered. Be sure the height of the tower is at least 30 ft (10 m) above trees and structures within 300 ft. (100 m) radius of the wind generator. The center of an open field is ideal and can reduce the tower height requirement.

Determine Location for Tower Base

Select a location for the tower base, and determine the direction in which the tower will lower and raise. If you will be using a vehicle to raise the tower, clear a path for the lift line from the lift anchor to the vehicle. A swivel pulley will be installed at the lift anchor, between the tower base and the vehicle. Mark the ground locations for the base and anchors.

This tower kit is designed to be installed on a flat surface. If you have a location that is on an incline or side of a hill you will need to have a local certified engineer review your installation. The design of this tower requires the gin pole (lift pipe) to rest on the eyebolt/anchor. If the gin pole was not supported from the ground it would cause unnecessary stresses and could force the tower to buckle. In addition, on an incline, your upper anchor should be installed on a dugout in order to make sure enough dirt is actually supporting the stresses of the anchor. If you are unsure of your design, and before you begin your project on a hill, we recommend you contact the head engineer at Southwest Windpower to make sure your installation is safe.

When your tower is being installed on an incline you must make sure that the side anchors and base anchor are level. The front and back anchors must be directly up and down slope with the gin pole on the downhill section. This will help raise the tower since the turbine will be resting uphill. Make sure the anchor points and base anchor are in line when sighted from anchor to anchor. This will ensure the forces on the guy wires are balanced properly.

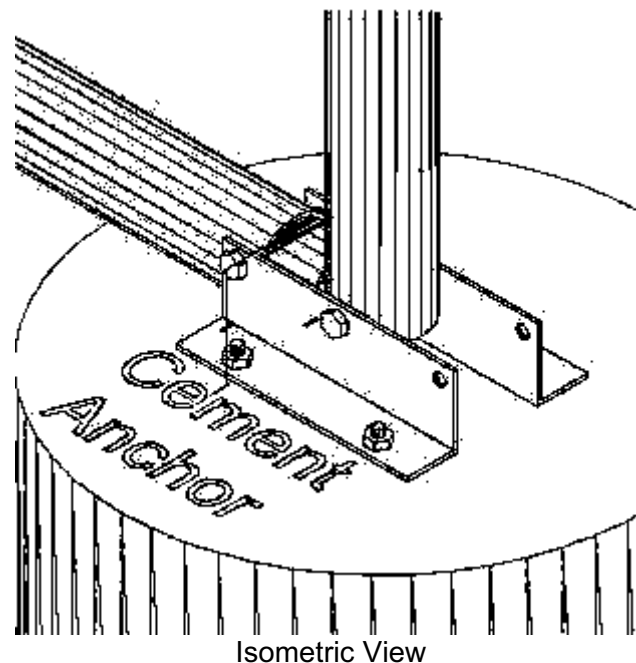

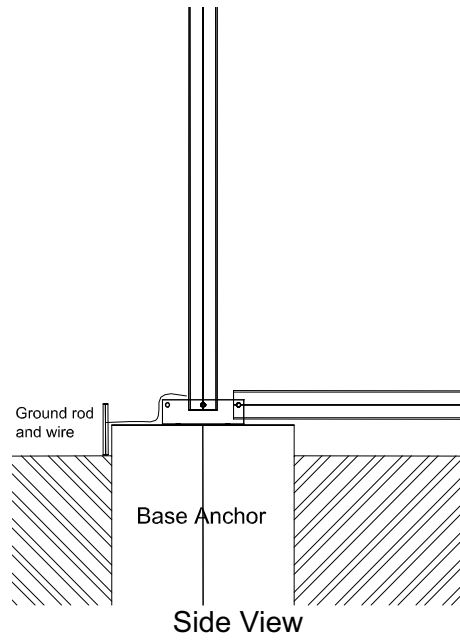

Figure 3.1: Base Anchor Layout

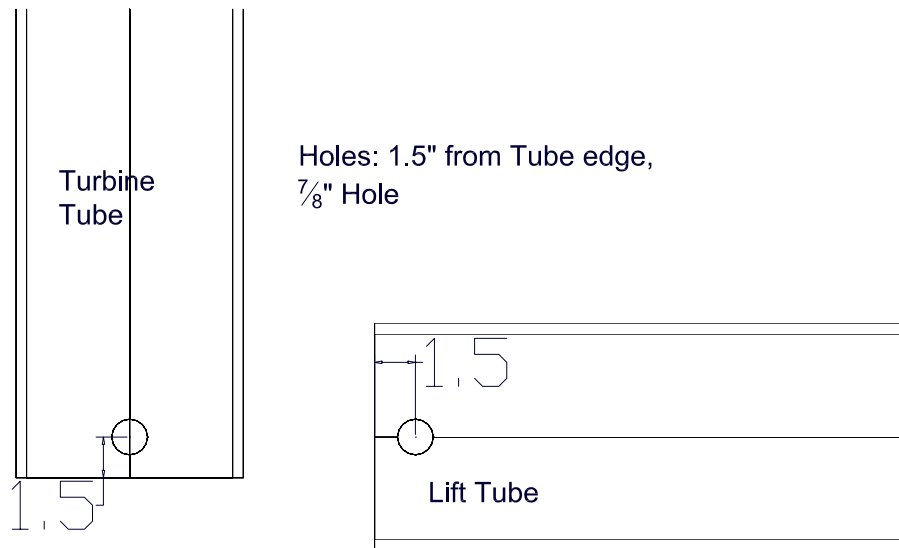

Figure 3.2: Base Anchor Detail View

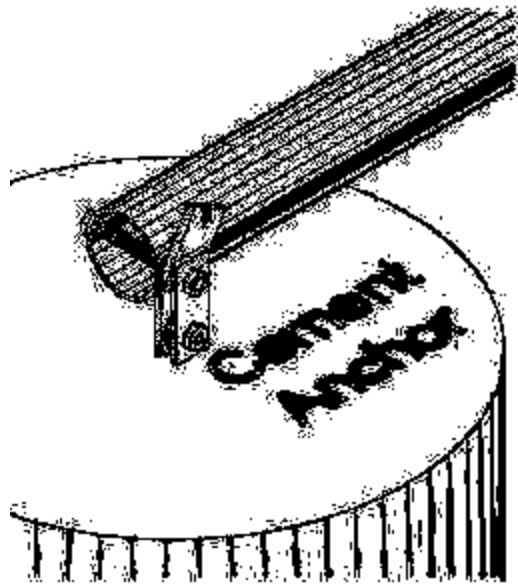

Figure 4.1: Ginpole Anchor Angle View

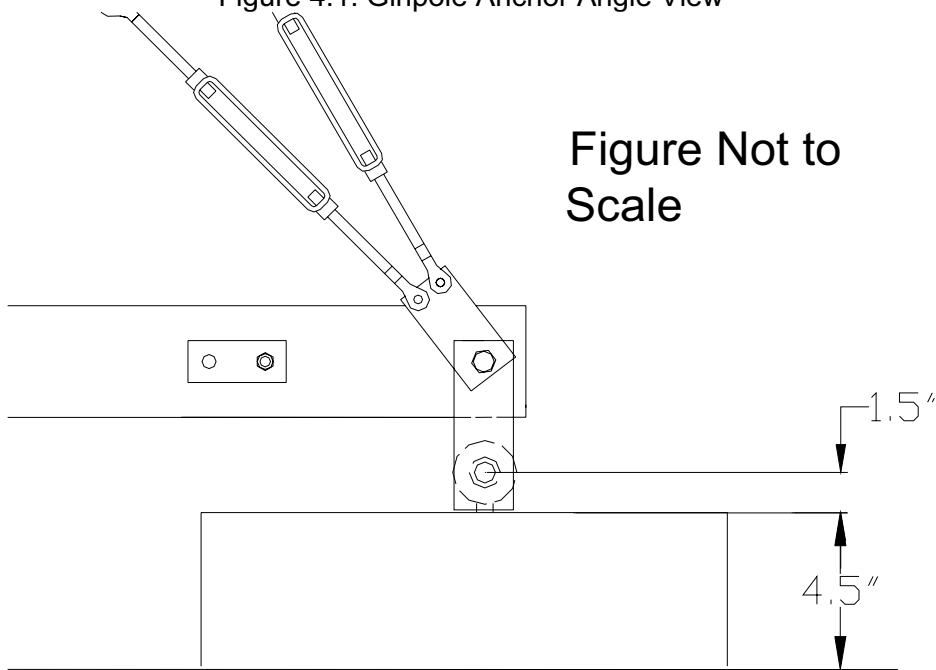

Figure 4.2: Side View of Ginpole Anchor (Eyebolt Flush with Concrete)

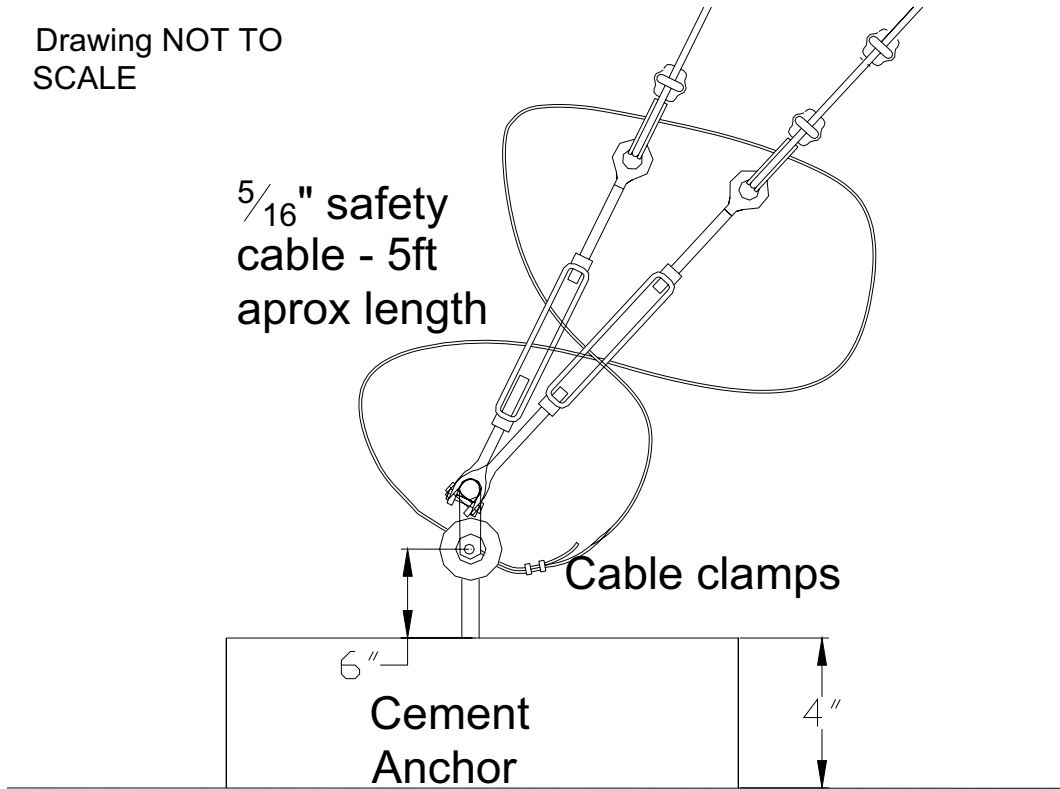

Figure 4.3: Concrete Anchor View (back and side anchors only)

Step 4: Tower Base & Guy Wire Anchor Assembly

Buried concrete anchors will work in any situation other than solid rock. A hole must be dug in the ground at the desired anchor point. The calculations made for this manual and anchor design are for clay soil, which is the worst-case scenario. All design considerations and notes included in this manual assume a clay soil situation. You can use the blueprints for other types of soil as well.

<i>Type of Soil</i>	<i>Will Concrete Anchor work?</i>
Sandy	Yes
Gravel	Yes
Solid Rock	No

Use the two 1" tube spacers along with two of the long 7/8" bolts to assemble the base angles in the proper orientation. The spacers make sure the distance between the angle plates is correct and to make the assembly of the tower base anchor easier. The length of the spacers is the same as the width of the 5" schedule 40 steel pipe. The spacers will be used as positioning devices allowing the angles to be perfectly spaced while the concrete sets. Once the concrete has solidified you can remove the spacers and install the bolts with the lift pipe and turbine pipe.

PRECAUTION: Make sure the flexible conduit coming down your turbine pipe has enough spacing to bend at the cement anchor. If there is not enough space you can create a groove (typically 1 inch deep) in the cement before it solidifies.

Use 2500-psi concrete and let cure for 28 days (mix ratio - contact your local concrete supplier if there are any questions) and pour the base and anchor foundations. The four 3/4" x 18" anchor bolts should be bolted to the base angles with the 3/4" split lock washer between the nut and the angle, and then wire wrapped to the rebar structure for the base foundation (see Figure 5). The four eyebolts should be wire wrapped to the rebar structure shown in Figure 6. The concrete is then poured around these structures. Level the foundation tops with a slight slope to assure that water will not pool around the anchor rods and base.

The base anchor should be 6 inches above ground level. The four guy wire anchors should be 4 inches above ground level (see Figure 2). The two side anchors should have the center of the 3/4" x 12" eyebolt located **6 inches** above the top of the concrete anchor (see Figure 4.3). The backside anchor and the lift-pipe anchor should have the center of the 3/4" x 8" eyebolts **1.5 inches** above the concrete anchor (see Figure 4.2). The lift anchor has hardware and plates that connect it to the lift-pipe anchor (see Figure 4.1 and 4.2), and if you do not level the anchors appropriately you will have problems installing the kit. Also, the anchor for the gin pole is offset to the side between 3 and 4 inches to accommodate the linkage hardware (see Figure 7). See Figure 4.2 and Figure 8 for details.

Step 5: Assembly of Pipe sections

The following steps have been taken before you reach this point:

1. You have dug 5 holes. Four Anchor holes and one base hole. You have made sure they are centered and at equal distances from the center hole. Review Figure 2, 4.2, 4.3, and 7 to understand the position of holes.
2. You have worked with a civil contractor, who has used our blueprints, to build anchor rods, installed eyebolts for anchors and base bolts for base anchor and poured the concrete. To make sure the base bolts are properly centered you have assembled the base angle with the spacers provided and poured the concrete. You have allowed 28 days for the concrete to solidify.
3. You now have the base anchor with the base angle and the four eyebolt anchors ready to be used. Now you are ready to assemble the pipe sections.

Pipe Assembly:

1. Your pipe has already been cut to length according to the Pipe Length Table.
2. The Guy tab holes have been drilled according to Figure 1.2.
3. The Guy tabs have been installed on the appropriate pipe lengths and now you are ready to assemble the pipe.
4. Align the pipe sections axially prior to installing the clamps. Do NOT attempt to align the pipe sections using the clamps.
5. Arrange the three couplers around the tower joint.
6. One seam should face the ground as shown in this picture below.
7. Be sure the pipe sections meet in the middle of the coupler.
8. The metal couplers are keyed so that the bolts go in the square holes.
9. Uniformly tighten all 27 fasteners to 30 ft-lbs. Then starting at one end of the clamp, torque each bolt to 60 ft-lbs, going around the clamp in a circular fashion and working toward the other end of the clamp.



When you finish assembling the gin pole and tower pipe the installation should look like Figure 10. Remember to have on hand wood pieces or bricks to support the pipe sections 7 inches above ground. This is important since you do not want to be moving the tower and lift-pipe sections around. They are very heavy! Remember to have help around to move the pipes into place. See figures 2 and 10 for details!

The last hole to be drilled is the one in the gin pole that connects it to the steel anchor links (see Figure 4.2). This hole cannot be drilled until the anchors are in place and the assembled gin pole is bolted to the base angles.

- Connect the two steel links to the eyebolt with the 7/8" x 3" hex bolt. The eyebolt hole end of the steel links will determine the location of the hole that must be drilled on the gin pole. This hole should be located near the centerline of the pipe.
- Fasten the three steel plates to the gin pole with the 7/8" x 8" hex bolt as shown in Figures 4.1 & 4.2.
- Connect a turnbuckle to each of the two holes in the center steel plate.

Step 6: Attaching Guy Wires

Now that the pipe sections are assembled you are ready to install the guy wires.

- Install a shackle to each of the two side anchor eyebolts and to the backside anchor eyebolt.
- Install two turnbuckles to each of these shackles. At this point you should have all eight turnbuckles connected to the anchors.
- Position each of these turnbuckles in the middle of its range so it can be used to either tighten or loosen the cable.
- Cut the steel cable into the proper lengths for the upper and lower guy cables. The following table indicates the individual cable lengths that are necessary for this tower. The last column in this table is the approximate working length of cable that will exist between the turnbuckle on the anchor and the tab on the tower pipe.

Note: You should have 20 feet of cable left over after cutting the guy cables. This last piece of cable should be cut into four 5' sections. These cable lengths will be used as backup security loops after the tower is erected and the guy cables are properly tensioned (see Figure 4.3).

Guy Wire Location (vertical location)	Size to cut steel cable (ft)	Approx. length from turnbuckle to guy tab (ft)
Lower level (35')	6 @ 60'	48 ft
Upper level (63')	4 @ 80'	70.5 ft

- Attach the side anchor guy wires to the gin pole as shown in Figure 7.
- Attach a thimble to the tab on the gin pole and also to the side anchor eyebolt. Note that the left and right guy wire for the *gin pole* are connected directly to the eyebolts and do not connect to the turnbuckles (the eight turnbuckles are only used for guy wires that come from the tower pipe).
- Guy wires should be as tight as possible pulling by hand. Six inches of side-to-side slack at the end of the lift pole is acceptable. Three cable clamps shall always be used to secure each end of the guy cables. Be sure that the forged side of the cable clamp is used on the cable that is under load (see Figure 9.2).

Note: Thimbles may need to be spread open to install them on your eyebolts. This can be done with a pair of pliers. Be sure to press the open end of the thimbles back together (with pliers) before attaching the guy wires. See Figure 9.1 for details.

- Attach upper and lower guy cables to the two side anchors. Again, use a cable thimble on each of the guy tabs, and also on the turnbuckles. The table in this section tells you

how long to cut these cables and also how long the approximate cable length should be after being attached to the turnbuckle and the tower pipe.

- You should have around five feet of cable on each end to make the connections with the cable clamps. Again, be sure that the forged side of the cable clamp is used on the cable that is under load (see Figure 9.2).
- Attach upper and lower backside guy cables from the tower pipe to the backside anchor. This is the anchor that is presently laying right next to the tower pipe. These are the guy cables that will prevent the tower from rotating past vertical when the tower is erected. It is very important that these cables are secured to the tower pipe before you try to raise the tower.
- Use the table in this section to estimate the length of these cables. Pulling it to a side anchor and placing a piece of tape on the wire at the distance of the turnbuckle on the side anchor can also estimate the rear wire length.
- The rear wire must then be attached to its respective anchor at the point marked by the tape. This should make its length approximately correct when the tower is up (again, it will be readjusted, so don't worry about a few inches one way or the other). **Make sure that none of the guy wires are crossed and that the side wires are straight without the rear wire crossed on top of them!**
- Attach the side and rear wires securely as shown in the drawing with three clamps on each wire. Use 30 ft-lb. of torque on each nut. It is important (for good strength) that the saddle part of each clamp is on the loaded (tower) side of the guy wire (see Figure 9.2).
- The last set of guy wires are the ones that connect the gin pole to the tower pipe. For now, attach these wires to the turnbuckles that are attached to the gin pole (see Figures 4.2, 8, & 10). You will have an easier time attaching these cables to the tower pipe if you make a mark on each of these cables at the estimated point of attachment with the guy tabs on the tower pipe. This can be done by measuring appropriate amount of cable (see Table) and then bend the cable to mark it. These cables will eventually be attached to the tower pipe after the gin pole has been raised.

Figures 7, 8, 9.1 and 9.2 show details on how the guy wires should be assembled. Make sure you measure the length of the guy wires correctly, otherwise they will not be the proper length and you will spend much time resetting them.

Leave about 6 inches of slack in the wires to allow for any misalignment or unnoted elevation differences (the wires will be adjusted more precisely later).

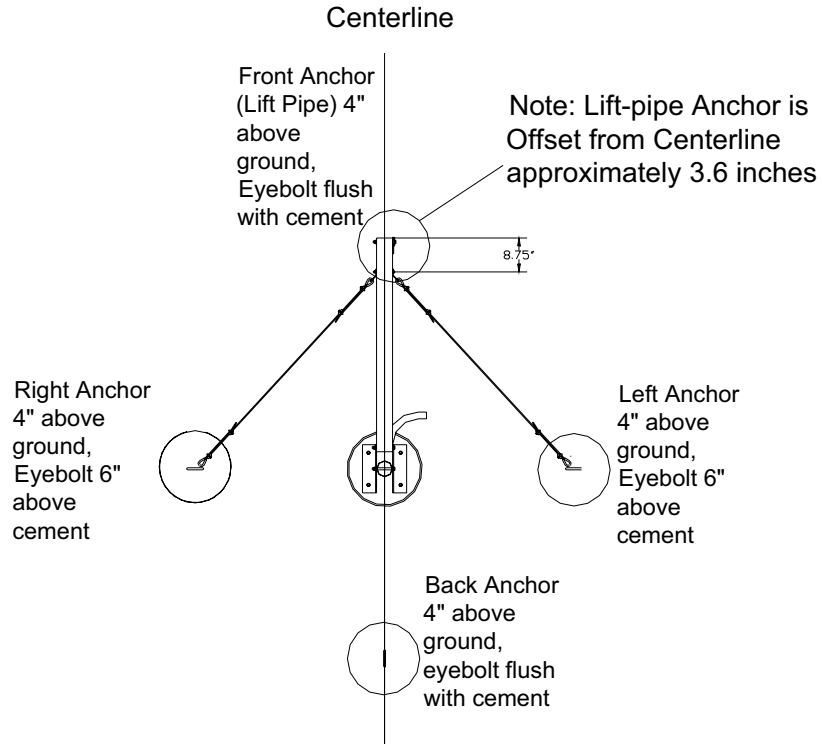

Figure 7: Birdseye View of Anchors and Lift-Pipe

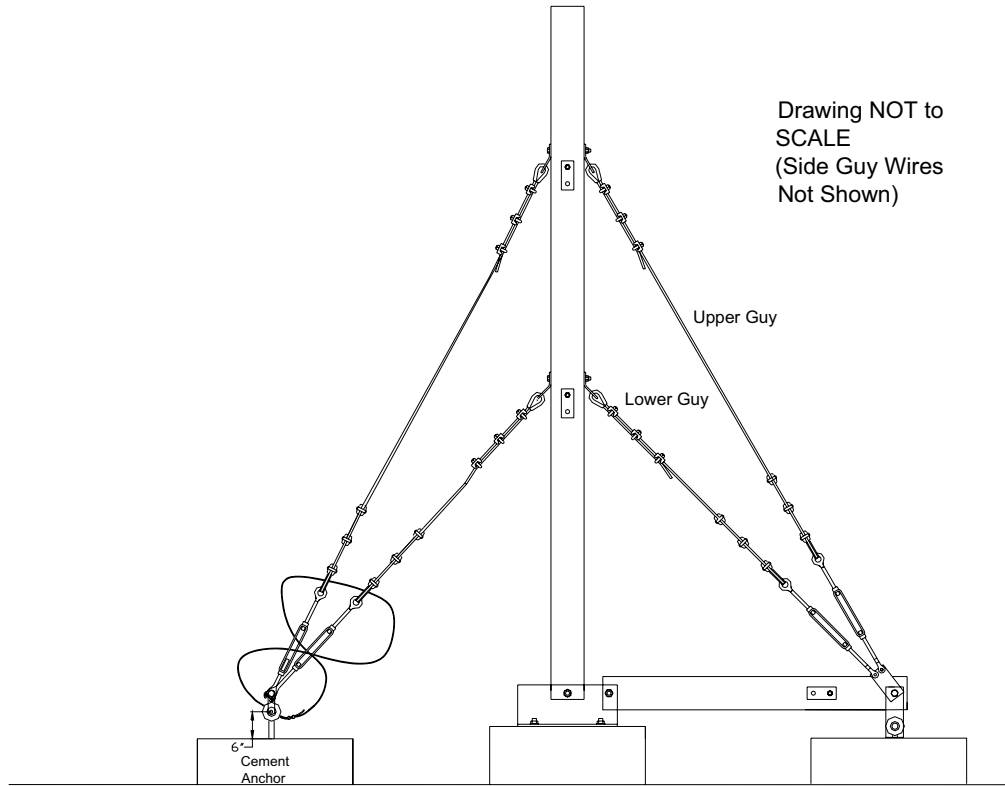

Figure 8: Tower Assembly Side View

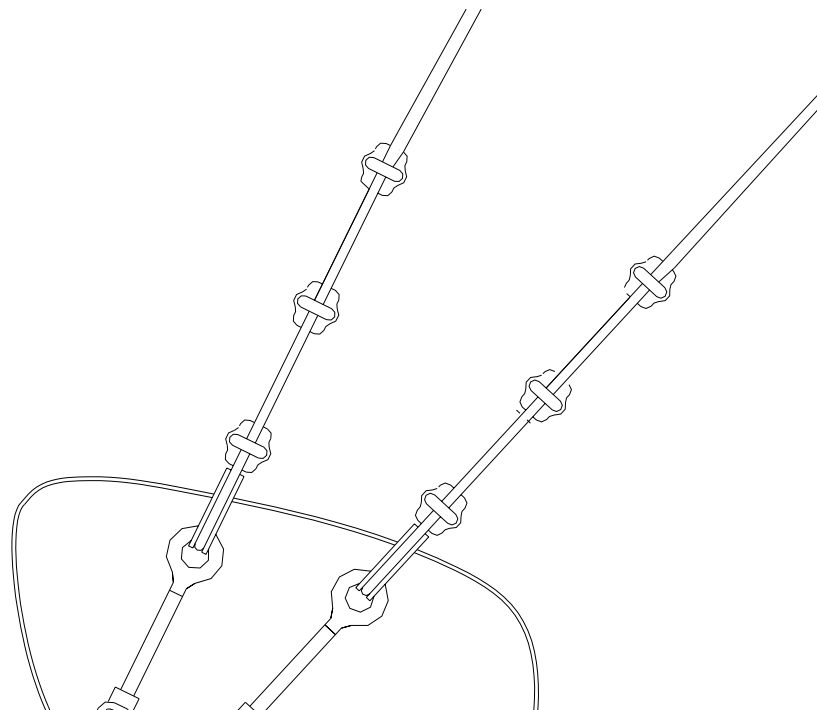

Figure 9.1 Turnbuckle and Guy Wire attachment

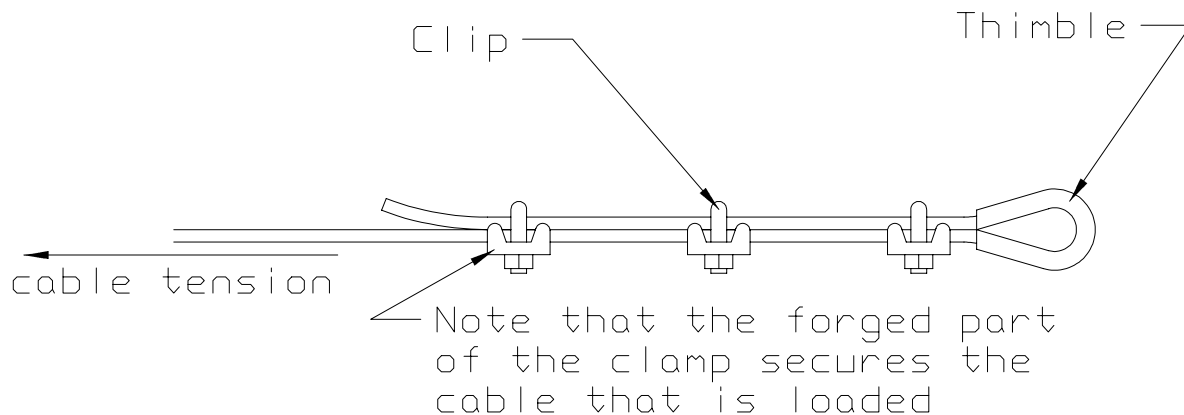

Figure 9.2

Step 7: Grounding the Tower

It is critically important that the tower be properly grounded before it is erected. Grounding will provide static and lightning protection for the turbine, tower, and the rest of your system. Typically, grounding is accomplished by driving an eight foot copper ground rod into the earth near the tower base. A wire is then used to connect the tower base to the ground rod (see Figure 3.1).

Grounding is a critical part of any tower installation. Not grounding your system will void your warranty AND cause damage to your turbine, and Balance of System (BOS). It is recommended to ground all guy wires to the same ground rod, especially in high lightning-strike areas. Consult your electrical contractor regarding local laws regarding the grounding of structures.

Step 8: Raising the Tower

CAUTION: RAISE THE TOWER ONCE PRIOR TO INSTALLING THE WIND GENERATOR TO ENSURE PROPER TOWER INSTALL

Important Note - Since you are about to lift the complete tower, we want to double check the procedure to make sure it is safe to continue. The following must be completed before proceeding with the following section:

- Tower pipe is properly grounded
- Tower pipe and gin pole must be connected to the tower base
- All sections of tower pipe and gin pole must be fitted together
- All guy wire tabs are fastened to tower pipe and gin pole
- Top of tower pipe is drilled to accommodate the tower insert for the wind turbine yaw shaft (see wind turbine owner's manual)
- All side guy cables for the tower and gin pole are connected to the side anchors. The cables should be properly tensioned so only minor modifications with the turnbuckles will be required after the tower is raised.
- The guy cables on the backside of the tower are connected to the anchor. This is the anchor that is next to the tower pipe laying on the ground. The cable length should be

similar to the cable lengths for the side anchors so that the tower pipe does not tilt past vertical during the tower erection.

- ❑ The guy cables that connect the tower pipe to the gin pole should be cut to the approximate length and attached to the turnbuckles on the gin pole.
- ❑ The 7/8" hole should be located and drilled in the gin pole that connects the anchor to the gin pole via the steel plates. The steel plates should be secured to the gin pole with the large through-bolt. The two turnbuckles should be attached to the smaller steel plate. (see Figure 4.2)
- ❑ All guy connections and bolts must be re-checked

1. The tower lift line must be connected to the gin pole before the gin pole is erected.
 - Remove the bolt that connects the two steel plates on the gin pole to the eyebolt anchor.
 - After removing this from the anchor, connect the plates back together with the bolt and tie the tower lift line to this bolt.

This is the rope that will eventually be used to raise the tower pipe. This rope should be around 80 feet long and must have a minimum breaking strength of 8000 lbs. The slack length of this rope should allow the gin pole to rotate just past vertical. This length is approximately 55' for a 35' gin pole. The tower lift line should be threaded through a pulley on the anchor. This pulley must be rated for at least 4500 lbs. A knot (or other means of anchoring) should be tied on the lift side of the pulley that will prevent more than 55' of rope from being let out.

2. The first step to raising the tower is to raise the gin pole. The gin pole for the 70' 500 tower weighs over 500 pounds so a secondary gin pole is necessary to raise the gin pole. One option for this secondary gin pole is to use a 10' ladder with a minimum rating of at least 250 pounds (see Figure 10). Do not use a stepladder for this because it must be able to rotate on its base. The ladder should straddle the tower pipe and be located near the tower base. An extension ladder with the proper rating should work just fine. The ladder should be given side-to-side support by tying a rope from the top of the ladder to each of the side anchors. This rope should have a minimum breaking strength of 4000 lbs. These two ropes will prevent the ladder from falling to either side during the gin pole erection. If a ladder is not available, then an A-Frame can be built out of 2x4s (see Figure 15).
3. It will be easier to attach the guy cables from the gin pole to the tower pipe in Step 7 if the cables are pre-bent at the estimated location of attachment to the tower pipe. This should be done before the gin pole is raised.
4. Connect the gin pole lift line to one of the turnbuckles on the gin pole. The minimum breaking strength for this rope must be 4000 lbs. The gin pole lift rope is then run across the top rung on the ladder before it goes through a pulley connected to the anchor. This pulley must be rated for at least 3000 lbs. The end of this rope should be attached to the bumper on the vehicle raising the gin pole. An alternative to a vehicle is to use an appropriately sized winch connected to the anchor (see Figure 10).
5. You will have to temporarily hold the ladder vertical while a second person begins to pull on the gin pole lift line. However, once the ladder will stay vertical due to the tension in the lift line, everyone should evacuate the area around the ladder and gin pole while it is being raised.

CAUTION: DO NOT ALLOW ANYONE NEAR THE LADDER OR GIN POLE WHILE RAISING THE GIN POLE

6. Slowly begin to pull on the gin pole lift line while a second person observes this procedure from a safe distance. Immediately stop this procedure if the ladder slips or if anything else does not seem right. Pay attention to the tension in the side guy cables on the gin pole while it is being raised. Stop if the guy cables either become excessively taut or slack. The ladder should fall to the ground after the gin pole is 10 feet off the ground. Continue to lift the gin pole until it just passes the vertical point. Gravity should then naturally move it a few degrees past center until the tower lift line holds it in place (see Figure 11).
7. Connect the upper and lower guy cables from the gin pole to the tower pipe. This will be made easier if you pre-bent the cables at the approximate location while the gin pole was still on the ground as described in step 3.

CAUTION: BE SURE THE GIN POLE IS SAFELY ANCHORED SO IT DOES NOT FALL ON THE PERSON CONNECTING THE LOWER GUY CABLE TO THE TOWER PIPE.

8. Move the vehicle to the other side of the tower and prepare it to begin pulling on the tower lift line. Be sure the tower lift line goes through a pulley on the anchor and is then securely attached to the vehicle.
 - Pull on the tower lift line until the tension in the guy cables just begins to lift the tower pipe off the ground.
 - Stop the vehicle and check that the gin pole and tower pipe are at a 90° angle (see Figure 12). The tension in the upper and lower cables should be equal. If the two pipes are not at a 90° angle or if the cables do not have equalized tension, then lower the gin pole just enough to be able to make adjustments in the cable length on the tower pipe (see Figure 11 and 12).
 - Repeat this process until the gin pole and tower pipe are at a 90° angle and the tension in the upper and lower guy cables are equalized.
9. Now you should be ready to erect the tower pipe for the first time. Do not raise the tower with a turbine on top until you have raised and lowered the tower several times without a turbine. It will be easier to make adjustments to the tower if there is not a turbine on the tower pipe. Also, it is important to learn how to *smoothly* raise and lower the tower before you try to do this with your new wind turbine.

CAUTION: NEVER STAND NEAR OR UNDER TOWER, GUYS, OR GIN POLE WHEN RAISING OR LOWERING TOWER

10. Raise tower slowly - carefully observing the tension in the side guys. If the side guys become taut, stop lifting and lower the tower and loosen the side guys that are too tight. Repeat if necessary. Excess tension in side guys due to anchors being lower than base pivot point will collapse the pipe. Raise tower until nearly vertical but with tension still on lift cable. A second person or the driver can now catch the lift pole and lower it gently to the ground. Allowing the lift pole to crash to the ground puts a serious strain on the back guys and other tower components. At the end of this step, the tower should be vertical (see Figure 13).

11. Check that the length of cable on the backside guy cables is not too slack or too taut. Minor adjustments can be made with the turnbuckles, but major adjustments should be made by lowering the tower and adjusting the length of cable through the cable clamps. Also, check that the cable length on the side guys is correct. Be sure to lower the tower if any adjustments need to be made.
12. Fasten the lift pole to the anchor. Using a long level against the side of the tower toward each anchor, adjust the lower turnbuckles until the tower is plumb at the base. Sighting up the tower, now tighten the upper turnbuckles until tower is straight. Guy wires should be just tight enough to eliminate sag.
13. After the tower pipe is vertical and the guy cables are properly tensioned, practice lowering and raising the tower several times without the turbine installed.
14. Once you are comfortable lowering and raising your tower, it is time to install the turbine. Lower the tower pipe so the end is resting on a support stand near the top guy cables (see Figure 14). This stand should hold the end of the tower pipe approximately 3 to 4 feet off the ground. You may need several wood blocks of different heights to support the tower.
15. Install the turbine to the top of the tower by following the instructions in the wind turbine owner's manual. The electrical wires for the wind turbine should be installed inside the tower pipe. Double check the rotor blades, tail, and tower insert are properly secured to the turbine and tower. The ends of the electrical wires from the wind turbine should be shorted to prevent the turbine from spinning while raising the tower.
16. Connect the tower to ground. You need to install a ground rod and using a AWG #10 solid copper wire or bigger connecting the tower to the rod. Consult your local building code specifications for grounding of towers. See Figure 3.1 Side view for details.
17. After the turbine is installed, raise the tower following the same procedure as described in step 10.
18. Secure the gin pole to the anchor and make any final adjustments to the tension in the guy cables with the turnbuckles.
19. Follow the turbine instruction manual on how to connect the turbine to the controller.
20. Congratulations! - You are now ready to begin harnessing power from the wind.

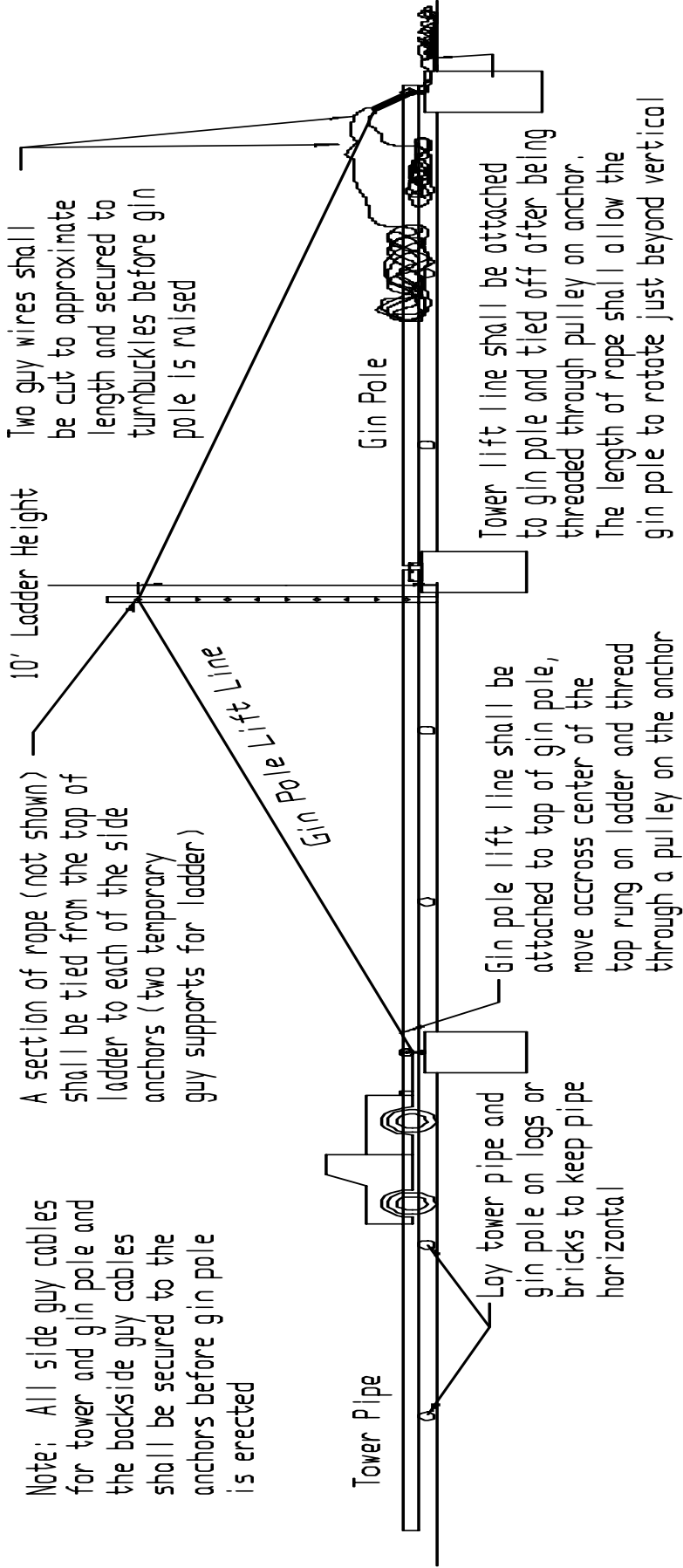
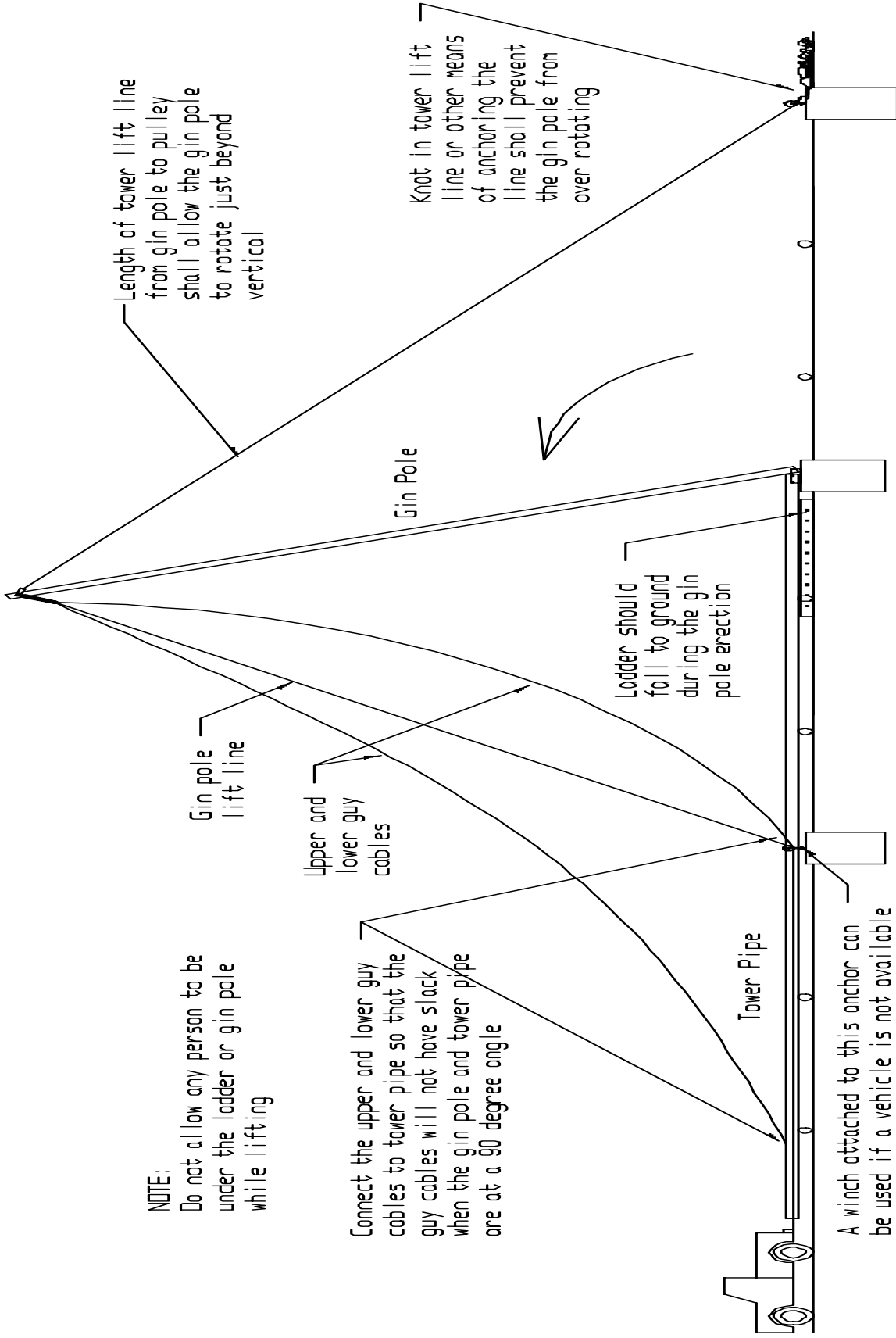

Figure 10



NOTE:
Do not allow any person to be under the ladder or gin pole while lifting

Connect the upper and lower guy cables to tower pipe so that the guy cables will not have slack when the gin pole and tower pipe are at a 90 degree angle

A winch attached to this anchor can be used if a vehicle is not available

Figure 11

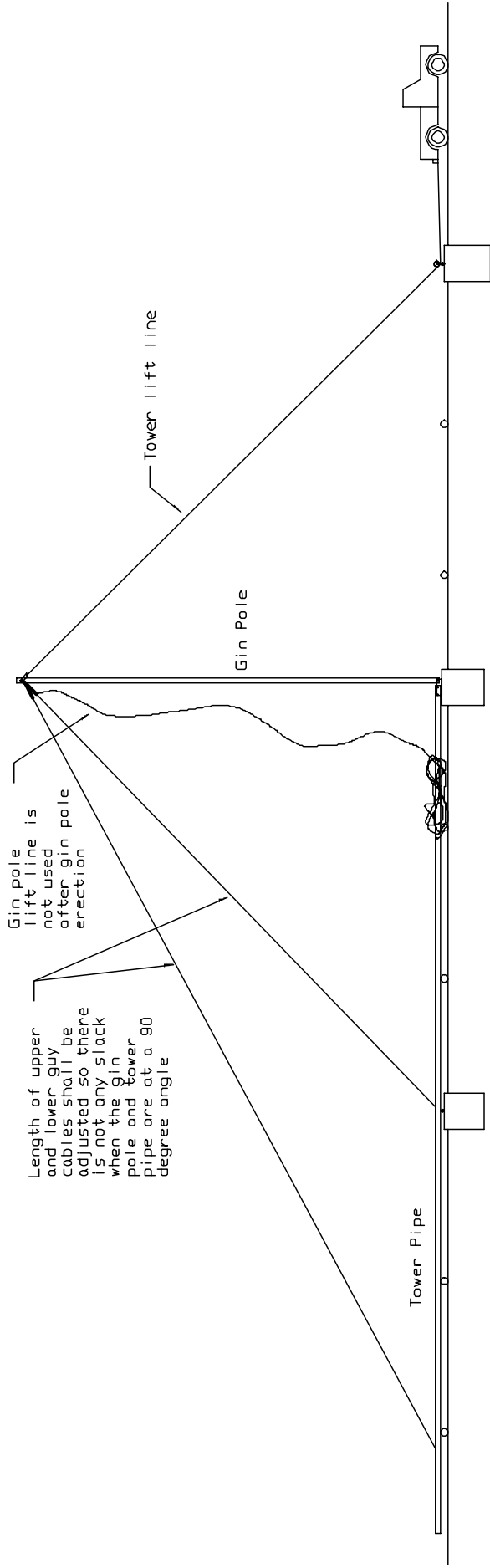

Figure 12

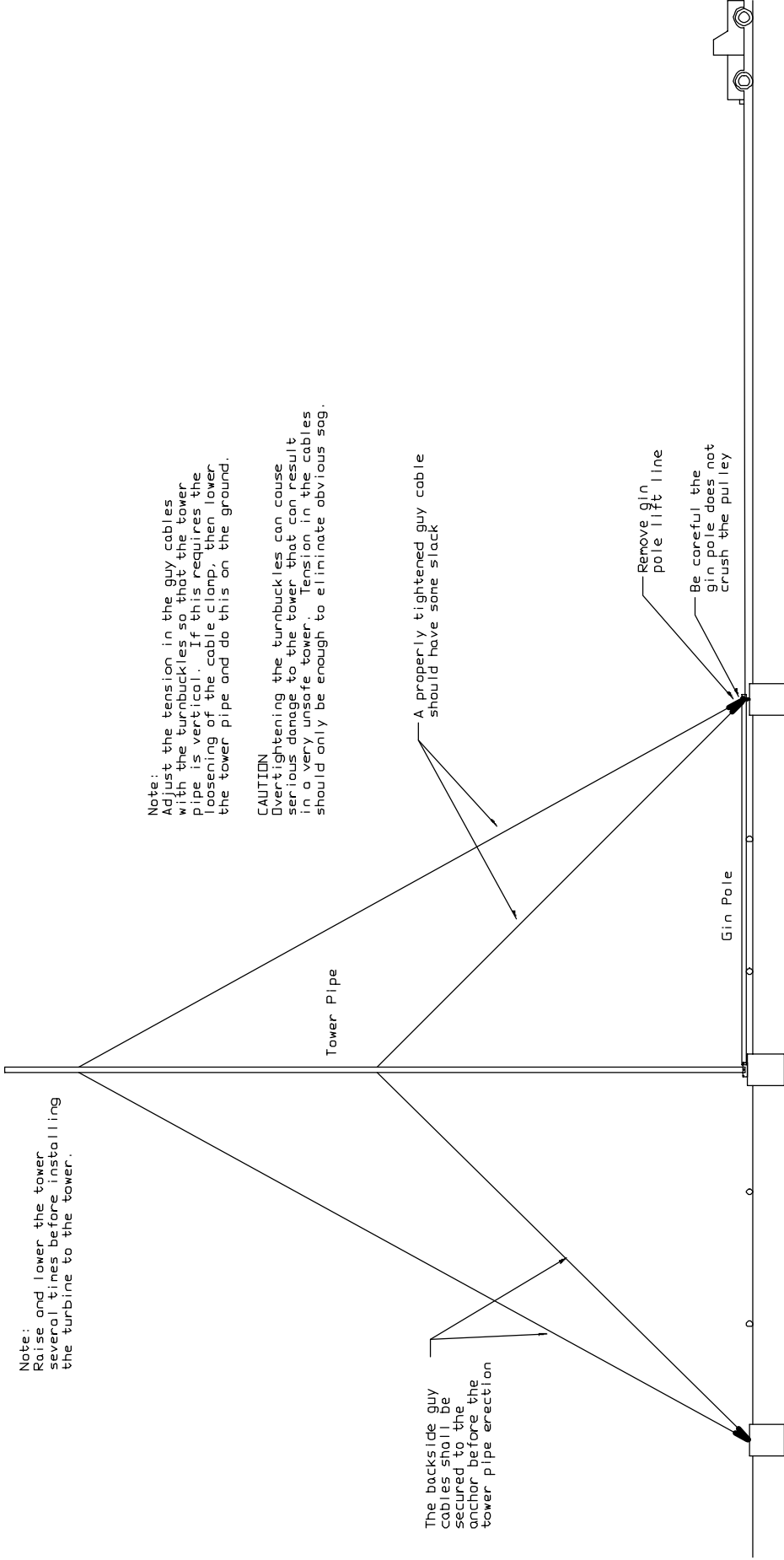

Figure 13

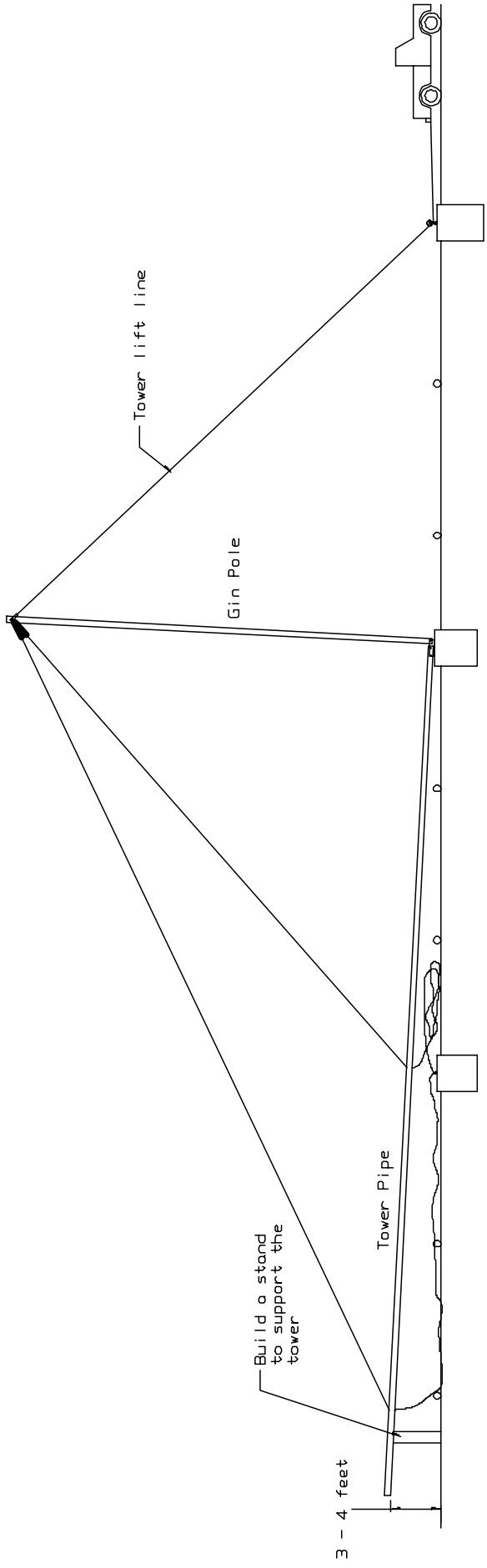

Figure 14

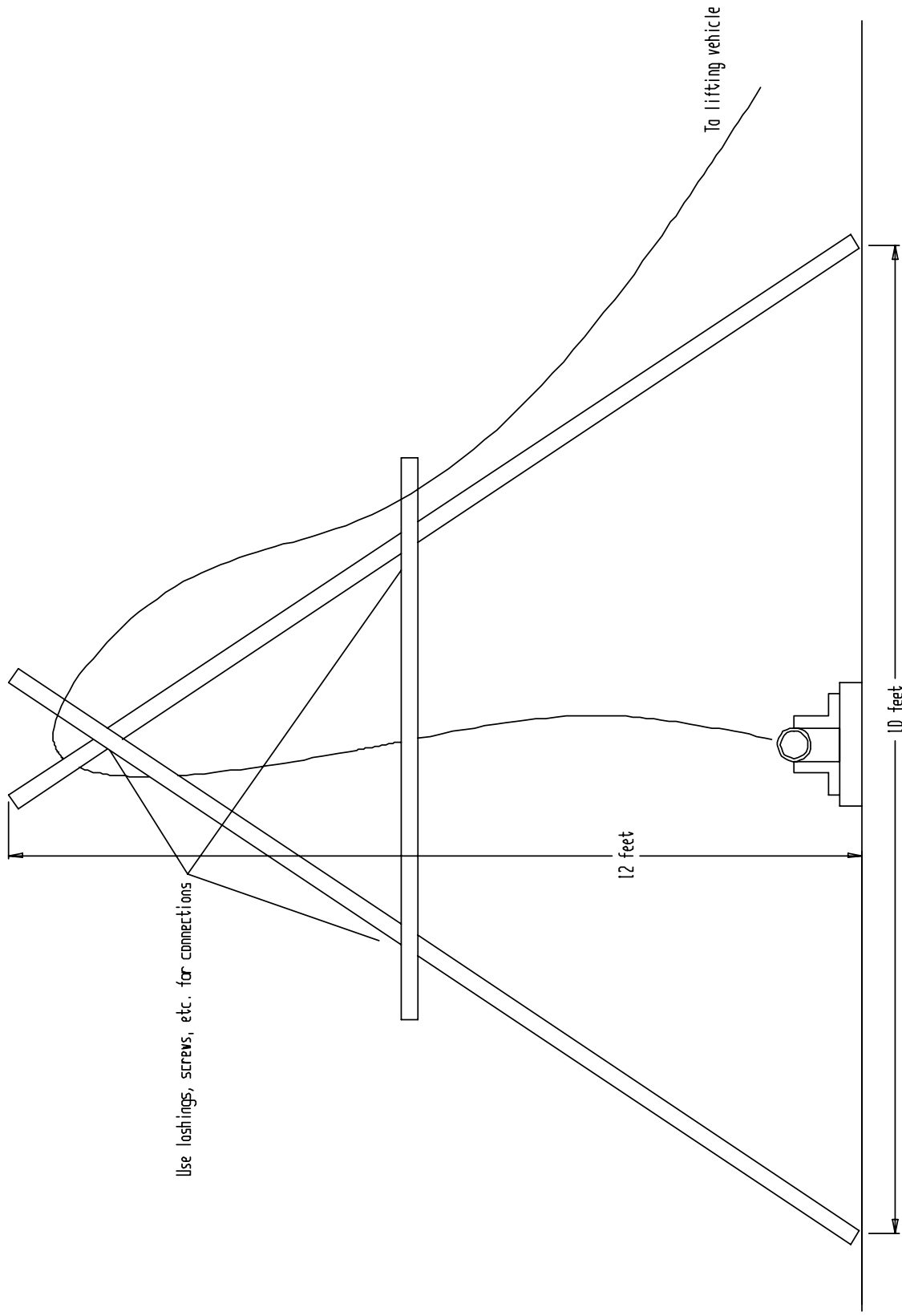

Figure 15